



DIAMOND⁺
deluxe collection

M
design
PASSION FOR FIRE



PASSION FOR FIRE
HOUT / BOIS



passion for fire



CEO - Bart Goovaerts

At M-design, fire has always been the basic principle for every design. We have chosen plain and straight lines to highlight the dancing flames. Allow yourself to be seduced by the warmth and strength of the fire, which is controlled by state-of-the-art technology to guarantee you comfort. Feel free to ask for advice. We feel at home in every type of interior. Ready for the initiation?

M-design stellt bei jedem Projekt das Feuer in den Mittelpunkt. Um die Flammen optimal wirken zu lassen, haben wir schlichte und klare Linien gewählt. Lassen Sie sich von der Wärme und der Kraft des Feuers verzaubern, verbunden mit dem Einsatz von Spitzentechnologie als Garantie für Ihre Beaglichkeit. Zögern Sie nicht, uns um Rat zu fragen, egal in welchen Stil Ihre Innenräume gehalten sind. Sind Sie bereit, die Magie des Feuers in Ihrem Haus zu erleben?



PASSION FOR FIRE

SUSTAINABLE CHOICE DIENACHHALTIGEGWAHL



lift-door appliances
Heizkamine
hochschiebbar

Luna Diamond Plus
Luna Diamond

10 horizontal
horizontal

20 vertical
vertikal

28 double-sided
Durchsicht

36 corner
Ecke

44 room divider

inserts
Einbaukassetten

Venus Green +

50 horizontal
horizontal

56 square
quadrat

58 double-sided
Durchsicht

Interra

60 vertical
vertikal

stoves
Kaminöfen

Venus HT

70 horizontal
horizontal

72 double-sided
Durchsicht

Outdoor fireplace
Kamin im Freien

74 850V BBQ



LunaDiamond+

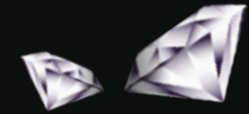

The intelligent Fireplace / Der intelligente Kamin

In a world where new technologies are more and more implemented into new building constructions and house renovations, modern technology is expected to live up to the highest efficiency. To respond to this increasing demand, M-Design comes with a solution to enjoy your wood fireplace even more. We introduce the 'Diamond plus range': a unique, efficient and user friendly technology. All Diamond PLUS models come standard delivered with a Swipe control. The free M-Design app also offers you the possibility to control the fireplace with your smartphone or tablet.

In einer Zeit wo immer strengere Normen zu erfüllen sind, hat M-design für Sie die passende ja sogar perfekte Lösung gefunden um Ihnen die Faszination des Flammenspieles zu ermöglichen. Die neue Diamant-PLUS Serie macht Ihr Zuhause nun zu einer Oase des Flammenspieles mit einer kinderleichten Bedienung: automatische Sichtscheibe, automatisches Funkenschutzgitter, saubere Verbrennung durch eine automatisch geregelte Verbrennung. Jedes Modell verfügt über ein digitales Bedienfeld daß Sie bequem alle Funktionen steuern läßt . Noch einfacher wird es wenn Sie sich unsere kostenlose App auf Ihr Smartphone legen und bequem vom Sofa aus Ihren M-design Kamin steuern.



TOUCH - SWIPE - ENJOY



RGB LED lighting
RGB LED Beleuchtung

Home screen
thermostat function

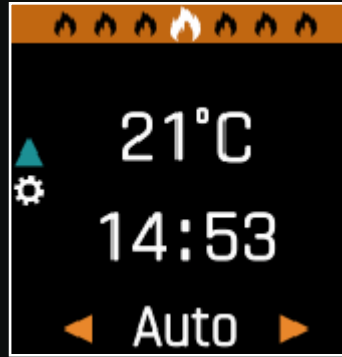

Startbildschirm mit
Thermostatfunktion

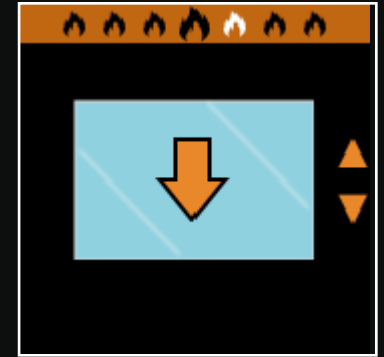

Opening and closing
window
Fenster öffnen und
schließen



Fan control
Ventilator Steuerung

Bluetooth connection to
the smartphone and tablet

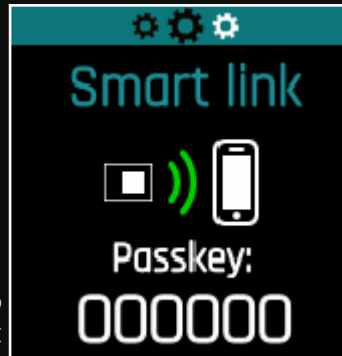

Bluetooth-Verbindung mit dem Smart-
phone und Tablet

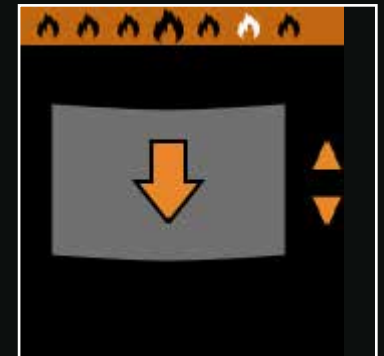

Opening and closing spark
screen
Funkenschutzgitter öffnen und
schließen



Flame height
control
Flammenhöhe
Steuerung

Sports mode

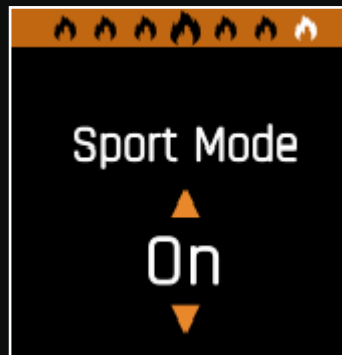

Sportmodus



Wood selection
Holzart Wahl

Discover the new Diamond Plus

Entdecke die neuen Diamond + Kamine

A multiple steps motor

enables the control of:

1. the automatic lift door
2. the automated spark screen
3. the automatically controlled temperature and flame height control
4. the automated regulation, depending on the chimney draft (Pascal measurement) and depending on the selected type of wood (soft-medium-hard)

Intelligent fire place

1. Automatic readjustment upon selection soft - medium - hard wood
2. Integrated dimmer control for fan
3. In case of a power failure, the appliance can still be controlled manually
4. The preprogrammed processor guarantees optimal combustion

Design swipe control

1. Bluetooth+ connection for tablet and smartphone
2. Control of the integrated RGB LED lighting (a 5 meter LED-strip is included in the price)
3. Automatic opening and closing of the spark screen and lift door
4. Silent fan control
5. Temperature control (the Swipe is also a thermostat)

Die Schrittmotoren

übernehmen folgende Funktionen:

1. elektrische Sichtscheibe
2. elektrisches Funkenschutzgitter
3. automatische Steuerung von Temperatur und Flammenspiel
4. Regulierung von die optimale Steuerung der Verbrennung durch Pascal-Messung im Abgasstutzen mit Berücksichtigung vom Wahl der Holzart

Intelligentes Feuer

1. Automatische Regelung bei der Wahl der Holzart (weich, mittel, hart)
2. Integrierte Lüftungssteuerung für den laufruhigen Ventilator
3. Die Scheibe kann automatisch sowie manuell bedient werden (praktisch falls Stromausfall) auch manueller Scheibenbedienung automatische Kalibrierung
4. Prozessor gesteuerte Regelung sorgt für die beste Verbrennung

Design Swipe-Screen Bedienung

1. Bluetooth-Verbindung Smartphone oder Tablett
2. Steuerung der RGB LED-Beleuchtung (LED Band von 5 Meter ist im Lieferung enthalten)
3. Automatisches und manuelles öffnen und schließen, der Schiebetür und des Funkenschutzgitters
4. Laufruhige Ventilator Steuerung
5. Temperaturregelung (Swipe ist auch Thermostat)

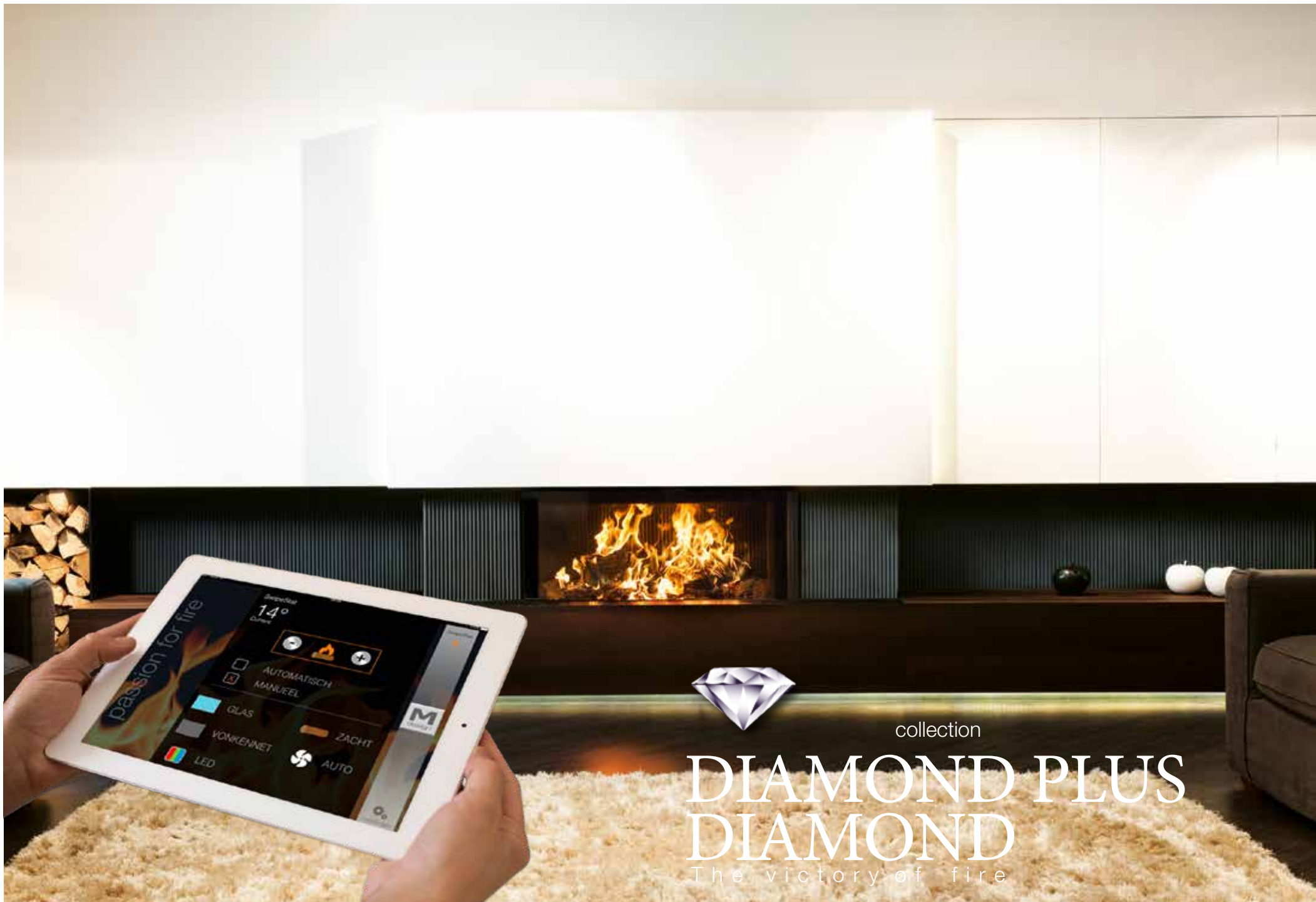

collection

DIAMOND PLUS DIAMOND

The victory of fire

Stoves with lifting doors

Kamine mit automatischer Sichtscheibe

The new Luna Diamond collection of M-design is “the fire” in the field of energy efficiency. The Diamond Series makes your home complete: automatic lift door*, clean combustion, a fine adjustment, a second decorative door (spark screen), a robust framework of 8 mm. and an interior of insulated cast-iron. A new patented, combustion system guarantees that every single woodlog will last longer.

The combustion process is so advanced that it obtains a particularly high efficiency of more than 80%. This means that less wood gets burned, which is better for the environment because it produces fewer exhaust fumes. The fine adjustment of the fire makes this stove with lifting doors unique. The lighting of the fire runs very smoothly and the clean combustion combined with the unique self-cleaning system results in lower maintenance.

The Diamond collection: an intelligent and sustainable solution.

Die neue Luna Diamond Serie von M-design ist „Feuer“ auf dem Gebiet der Energieeffizienz. Die Diamond Serie macht Ihr zu Hause bequemer: Automatisch zu öffnen Sichtscheibe*, saubere Verbrennung, eine effizientere Regulierung des Abbrandes, ein integriertes Funkenschutzgitter, einen robusten Rahmen von 8mm und eine Feuerraumauskleidung aus Gusseisen. Das neue patentierte Verbrennungssystem erzeugt einen Wirkungsgrad von über 80%. Somit kann aus jedem Stück Holz die maximale Leistung geholt werden. Sie benötigen weniger Holz und schonen somit die Umwelt und Ihren Geldbeutel. Die Möglichkeit der Feineinstellung des Abbrandes und die Schiebetür machen den Feuergenuss einzigartig. Durch die saubere Verbrennung und das Scheibenspülsystem wird ein einzigartiges Flammenspiel erzeugt.

Die Diamond Kollektion: Eine intelligente und nachhaltige Lösung!

* available in Luna Diamond PLUS / *verfügbar in Luna Diamond PLUS

Luna Diamond (Plus)



sided stove / einseitig page/Seite

Luna 700 H Diamond (Plus)		10-11
Luna 850 H Diamond (Plus)		12-13
Luna 1000 H Diamond (Plus)		14-15
Luna 1150 H Diamond (Plus)		16-17
Luna 1300 H Diamond (Plus)		18-19
Luna 550 V Diamond (Plus)		20-21
Luna 850 V Diamond (Plus)		22-23
Luna 1000 V Diamond (Plus)		24-25
Luna 1150 V Diamond (Plus)		26-27

double-sided / Durchsicht

Luna 850 DH Diamond (Plus)		28-29
Luna 1150 DH Diamond (Plus)		30-31
Luna 850 DV Diamond (Plus)		32-33
Luna 1000 DV Diamond (Plus)		34-35

corner stove / Eckmodelle

Luna 800 DC Diamond		36-37
Luna 1000 DC Diamond		38-39
Luna 900 CL/CR Diamond		40-41
Luna 1100 CL/CR Diamond		42-43
Luna 750 RD Diamond		44-45
Luna 1000 RD Diamond		44-45

Luna 700 H Diamond (Plus)

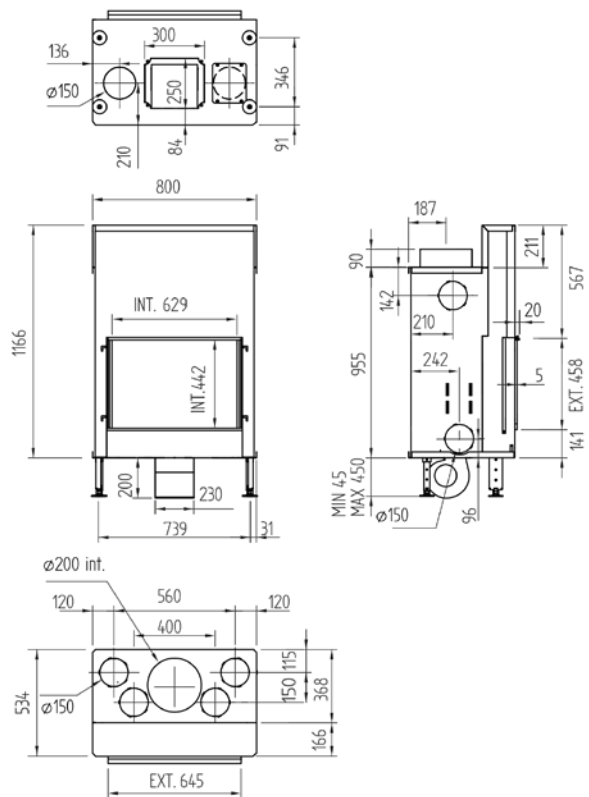

output / Leistung	4-12 KW
efficiency / Wirkungsgrad	84 %
weight / Gewicht	190 kg
finished size / sichtbare Abmessung	629 x 442 mm
flue connection / Abgasrohr	ϕ 200 mm
chimney / Schornsteindurchmesser	200/200





Luna 850 H Diamond (Plus)

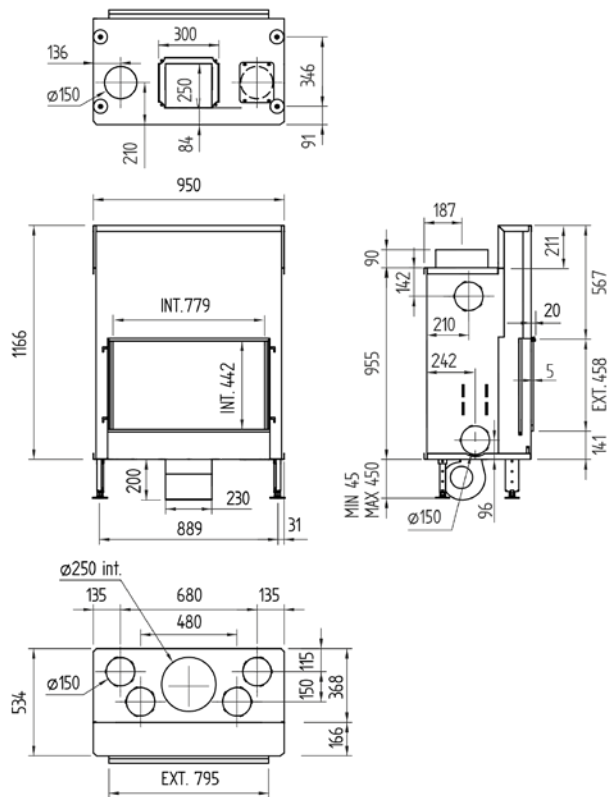

output / Leistung	5-13 KW
efficiency / Wirkungsgrad	83 %
weight / Gewicht	220 kg
finished size / sichtbare Abmessung	779 x 442 mm
flue connection / Abgasrohr	$\varnothing 250$ mm
chimney / Schornsteindurchmesser	200/200





Luna 1000 H Diamond (Plus)

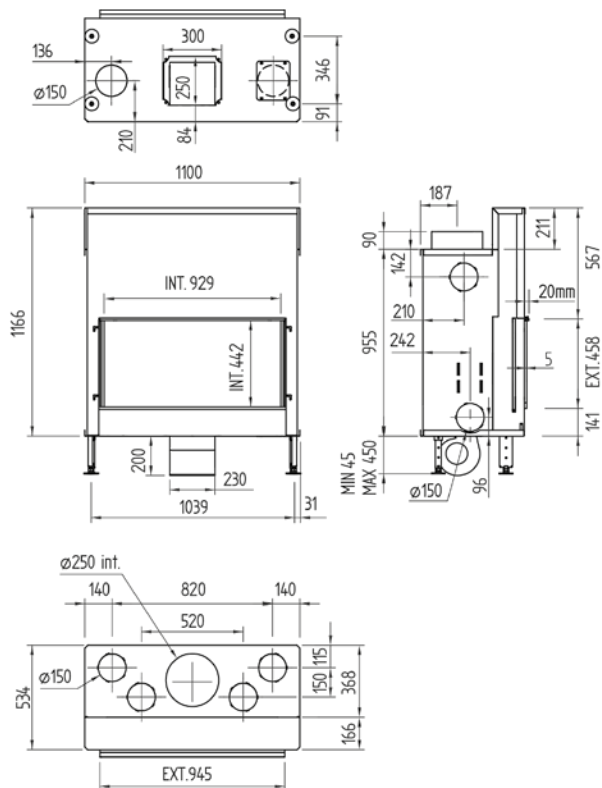

output / Leistung	5-14 KW
efficiency / Wirkungsgrad	82 %
weight / Gewicht	245 kg
finished size / sichtbare Abmessung	929 x 442 mm
flue connection / Abgasrohr	$\varnothing 250$ mm
chimney / Schornsteindurchmesser	200/200





Luna 1150 H Diamond (Plus)

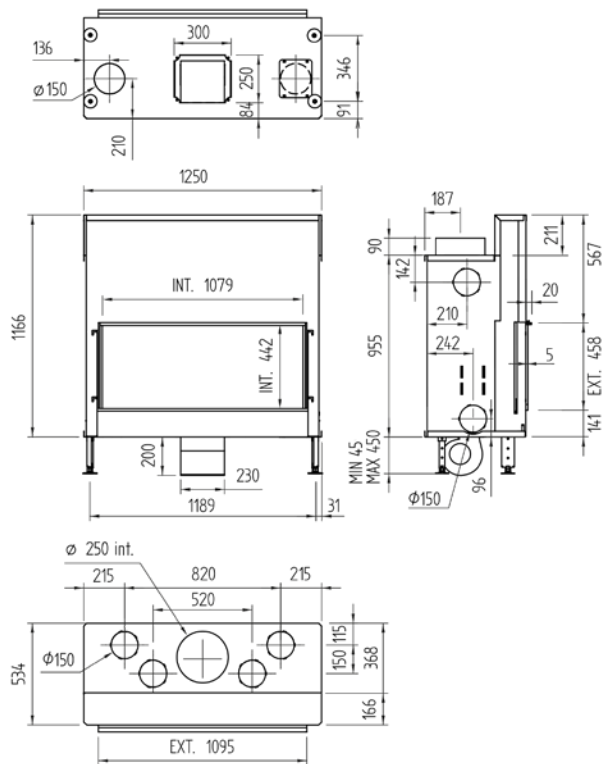

output / Leistung	6-15 KW
efficiency / Wirkungsgrad	82 %
weight / Gewicht	270 kg
finished size / sichtbare Abmessung	1079 x 442 mm
flue connection / Abgasrohr	$\phi 250$ mm
chimney / Schornsteindurchmesser	200/200





Luna 1300 H Diamond (Plus)

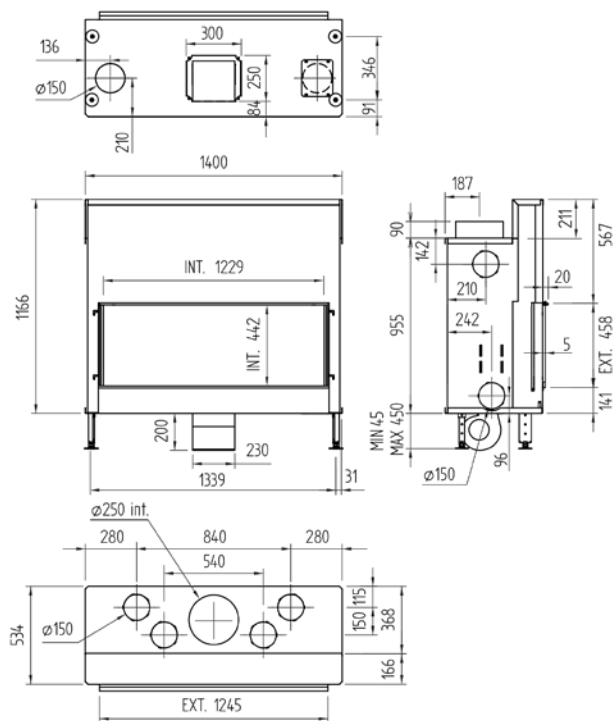

output / Leistung	7-16 KW
efficiency / Wirkungsgrad	81 %
weight / Gewicht	295 kg
finished size / sichtbare Abmessung	1229 x 442 mm
flue connection / Abgasrohr	Ø 250 mm
chimney / Schornsteindurchmesser	200/200



Luna 550 V Diamond (Plus)

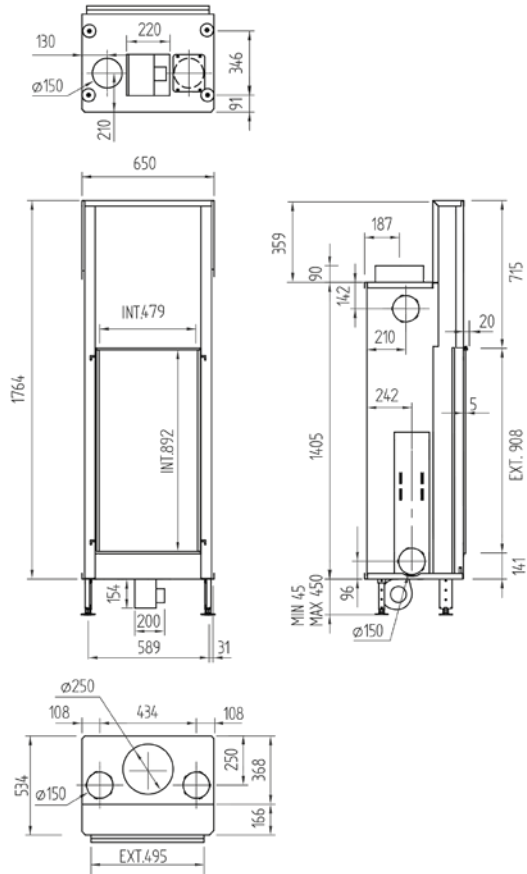

The spark screen and cast iron rear wall are not possible for this model.
In diesem Modell sind der Funkenschutzgitter und Gusseisen Innenausstattung nicht verfügbar

output / Leistung	5-12 KW
efficiency / Wirkungsgrad	80 %
weight / Gewicht	230 kg
finished size / sichtbare Abmessung	479 x 892 mm
flue connection / Abgasrohr	\varnothing 250 mm
chimney / Schornsteindurchmesser	200/200





Luna 850 V Diamond (Plus)

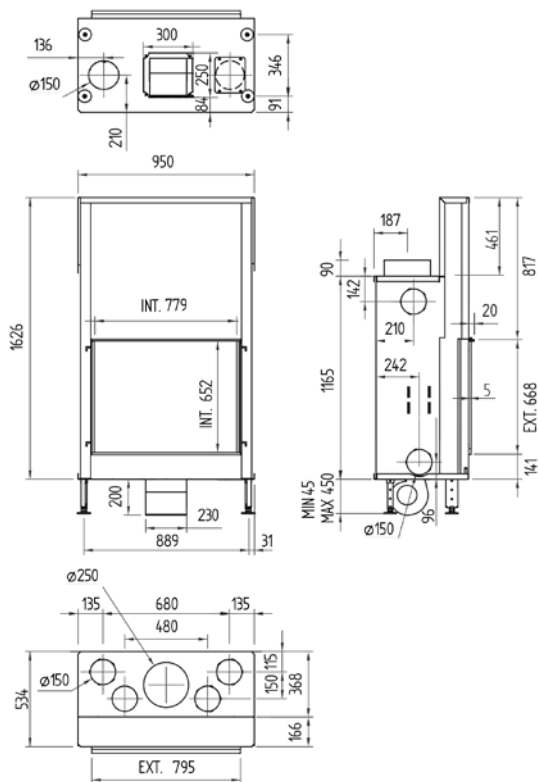

output / Leistung	7-14 KW
efficiency / Wirkungsgrad	80 %
weight / Gewicht	260 kg
finished size / sichtbare Abmessung	779 x 652 mm
flue connection / Abgasrohr	$\varnothing 250$ mm
chimney / Schornsteindurchmesser	200/200





Luna 1000 V Diamond (Plus)

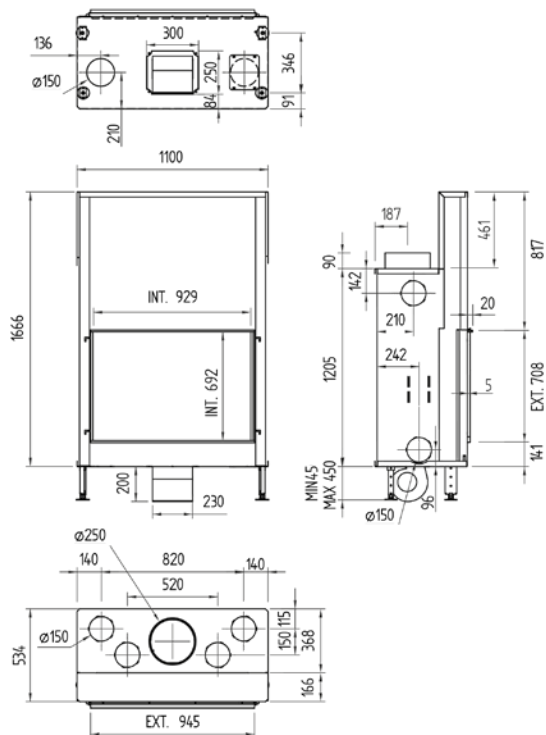

output / Leistung	8-16 KW
efficiency / Wirkungsgrad	79 %
weight / Gewicht	290 kg
finished size / sichtbare Abmessung	929 x 692 mm
flue connection / Abgasrohr	$\varnothing 250$ mm
chimney / Schornsteindurchmesser	200/200





Luna 1150 V Diamond (Plus)

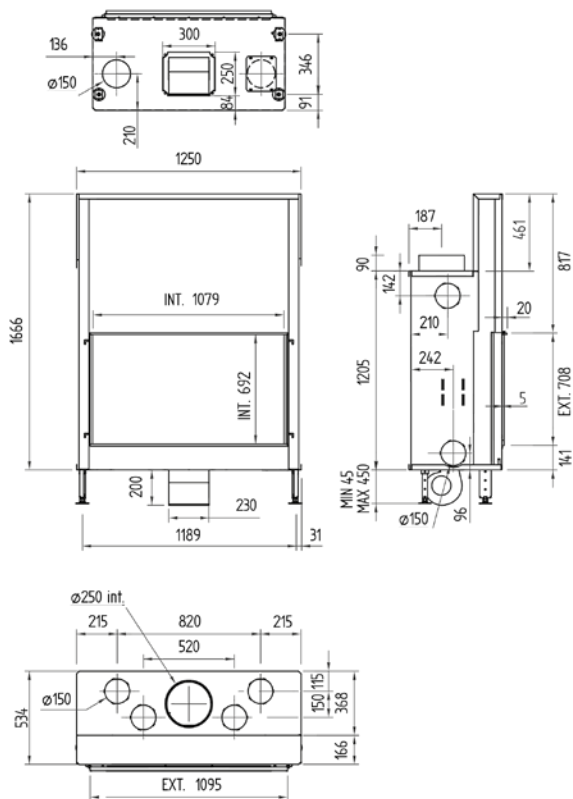

output / Leistung	9-18 KW
efficiency / Wirkungsgrad	78 %
weight / Gewicht	320 kg
finished size / sichtbare Abmessung	1079 x 692 mm
flue connection / Abgasrohr	$\varnothing 250$ mm
chimney / Schornsteindurchmesser	200/200





Luna 850 DH Diamond (Plus)

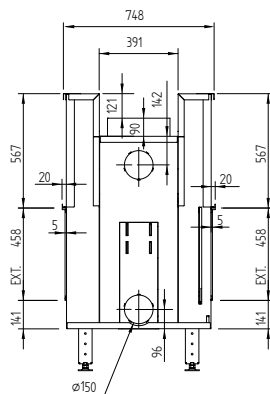
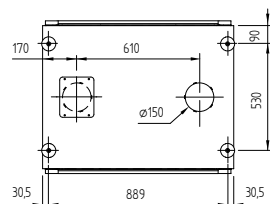
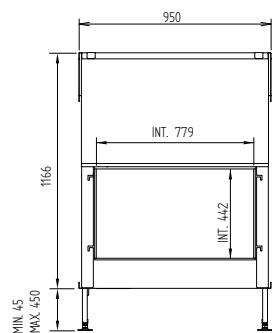
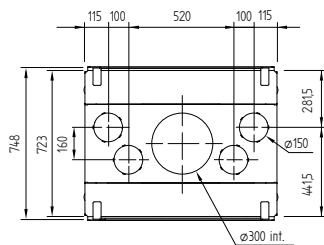

double-sided / Durchsicht

Fan not possible
Ventilator nicht möglich



output / Leistung	6-12 KW
efficiency / Wirkungsgrad	76 %
weight / Gewicht	280 kg
finished size / sichtbare Abmessung	779 x 442 mm
flue connection / Abgasrohr	Ø 300 mm
chimney / Schornsteindurchmesser	250/250





Luna 1150 DH Diamond (Plus)

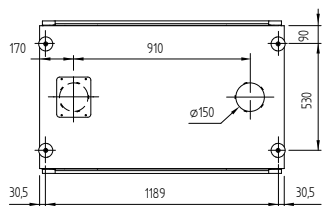
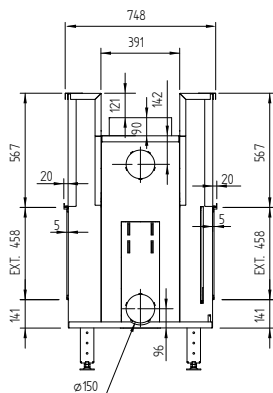
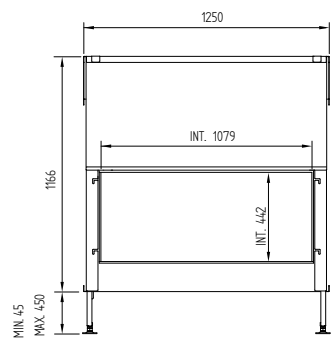
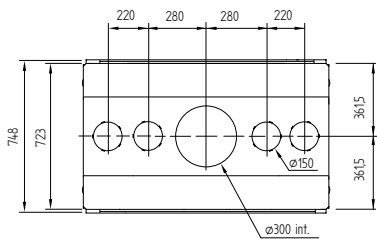

double-sided / Durchsicht

Fan not possible
Ventilator nicht möglich



output / Leistung	7-16 KW
efficiency / Wirkungsgrad	75 %
weight / Gewicht	345 kg
finished size / sichtbare Abmessung	1079 x 442 mm
flue connection / Abgasrohr	Ø 300 mm
chimney / Schornsteindurchmesser	250/250





Luna 850 DV Diamond (Plus)

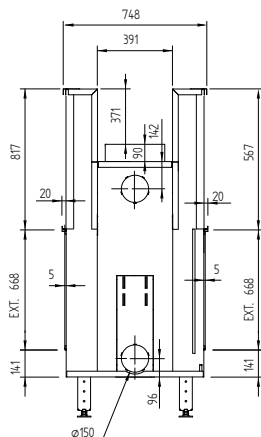
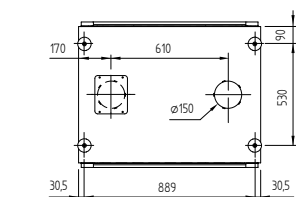
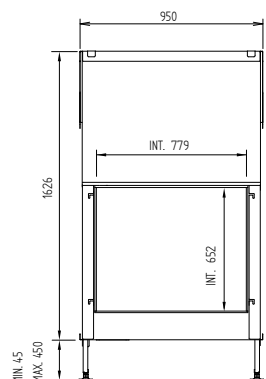
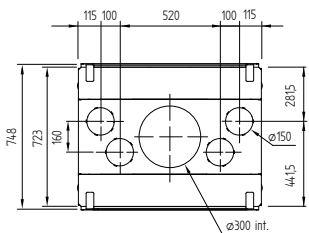

double-sided / Durchsicht

Fan not possible
Ventilator nicht möglich



output / Leistung	5-14 KW
efficiency / Wirkungsgrad	76 %
weight / Gewicht	330 kg
finished size / sichtbare Abmessung	779 x 652 mm
flue connection / Abgasrohr	Ø 300 mm
chimney / Schornsteindurchmesser	250/250





Luna 1000 DV Diamond (Plus)

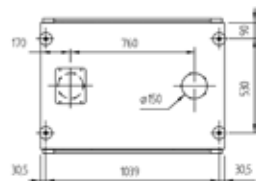
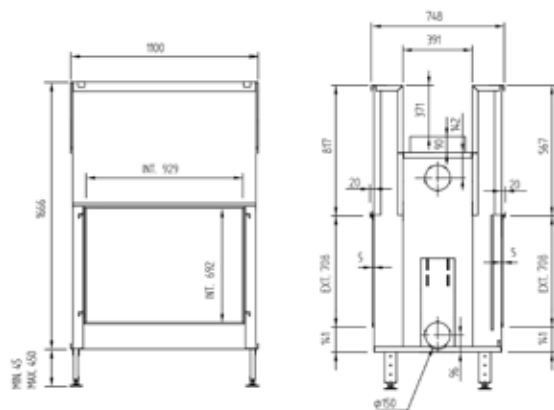
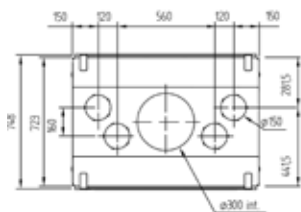

double-sided / Durchsicht

Fan not possible
Ventilator nicht möglich



output / Leistung	7-16 KW
efficiency / Wirkungsgrad	75 %
weight / Gewicht	370 kg
finished size / sichtbare Abmessung	929 x 692 mm
flue connection / Abgasrohr	Ø 300 mm
chimney / Schornsteindurchmesser	250/250





Luna 800 DC Diamond

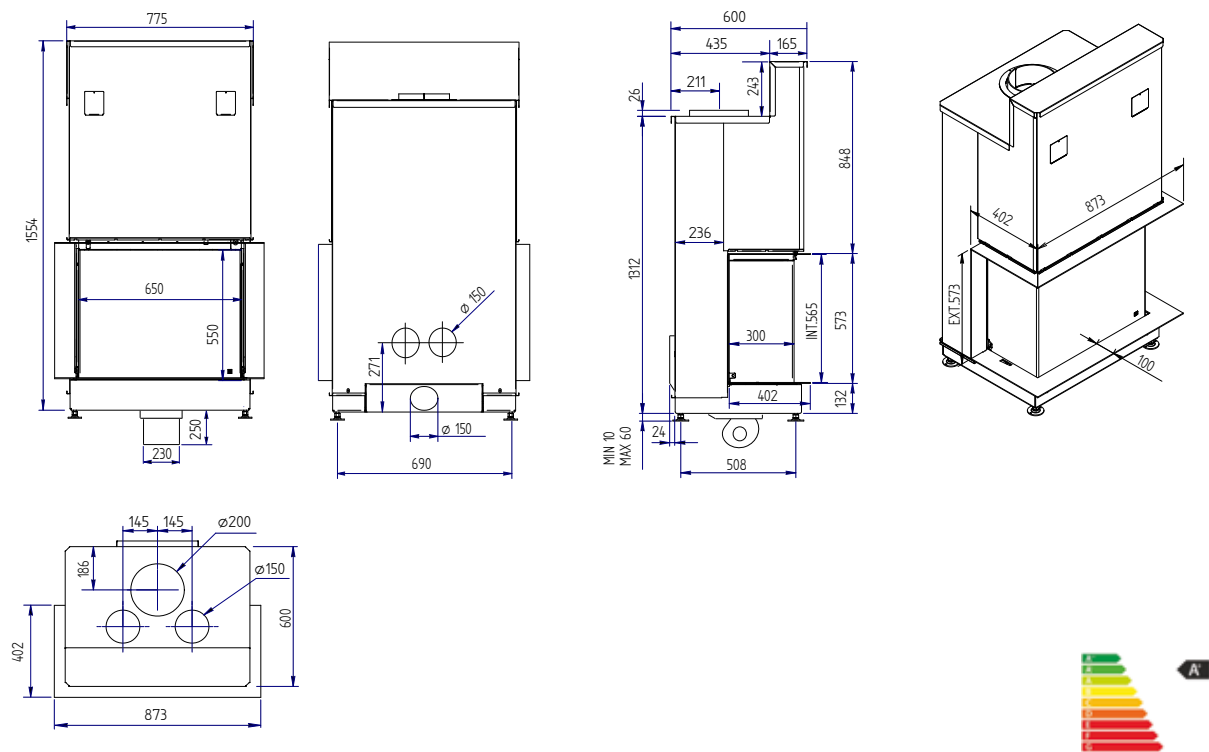

output / Leistung	7-12 KW
efficiency / Wirkungsgrad	76 %
weight / Gewicht	240 kg
flue connection / Abgasrohr	$\varnothing 200$ mm
chimney / Schornsteindurchmesser	200/200

Automatic door and spark screen not possible.
Automatische Sichtscheibe und Funkenschutzgitter nicht möglich



Luna 1000 DC Diamond

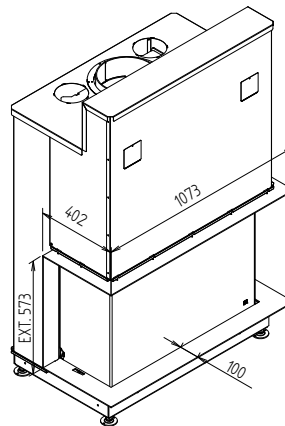
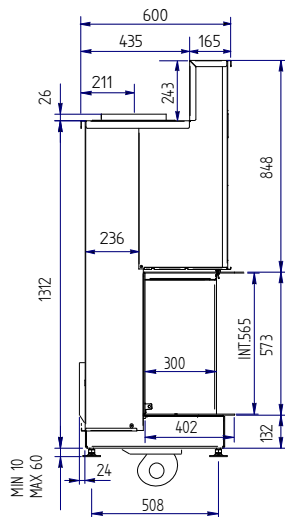
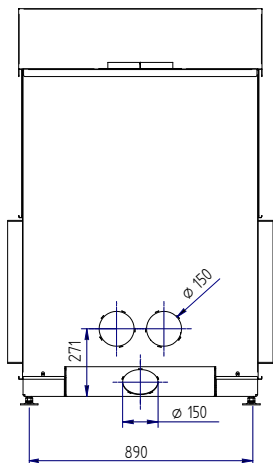
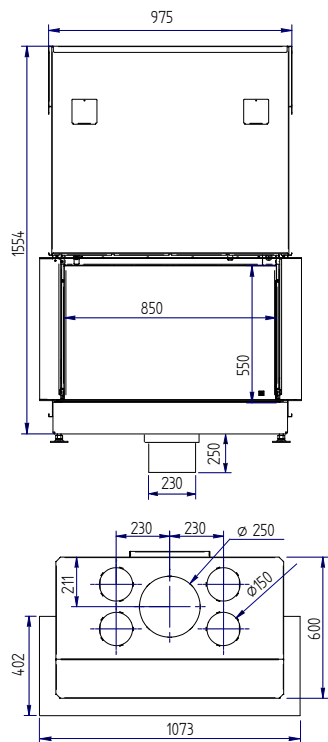

output / Leistung	8-14 KW
efficiency / Wirkungsgrad	76 %
weight / Gewicht	260 kg
flue connection / Abgasrohr	Ø 250 mm
chimney / Schornsteindurchmesser	250/250

Automatic door and spark screen not possible.
Automatische Sichtscheibe und Funkenschutzgitter nicht möglich



Luna 900 CL/CR Diamond

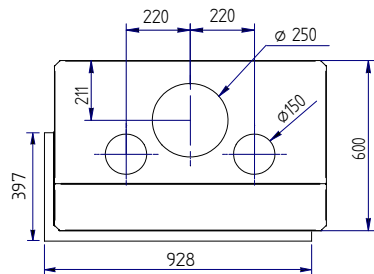
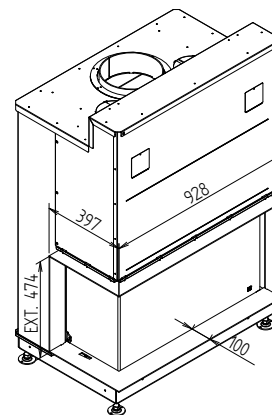
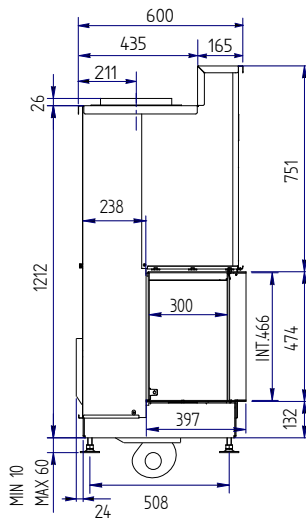
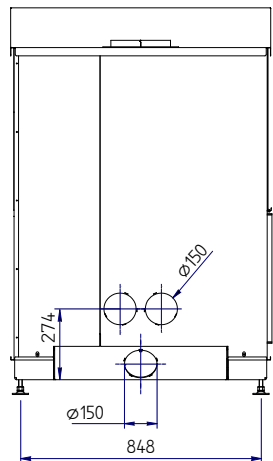
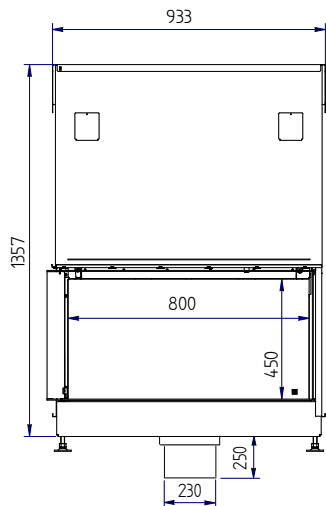

Plan = Luna 900 CL



output / Leistung	9-15 KW
efficiency / Wirkungsgrad	79 %
weight / Gewicht	300 kg
flue connection / Abgasrohr	Ø 250 mm
chimney / Schornsteindurchmesser	200/200

Automatic door and spark screen not possible.
Automatische Sichtscheibe und Funkenschutzgitter nicht möglich





Luna 1100 CL/CR Diamond

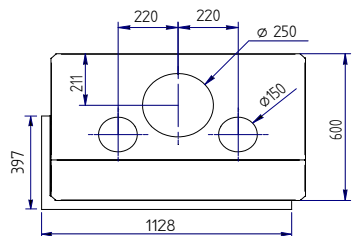
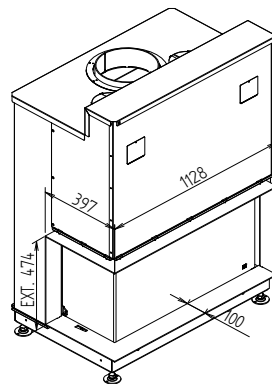
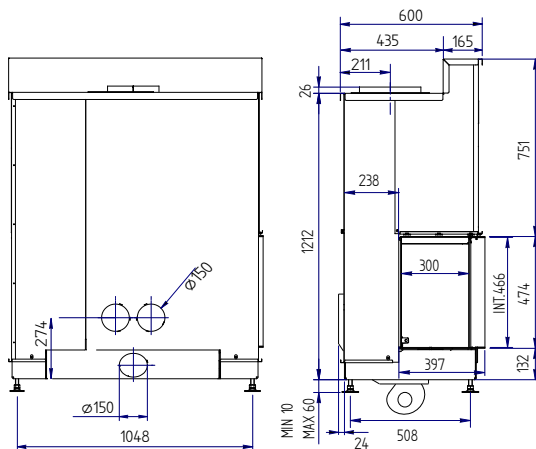
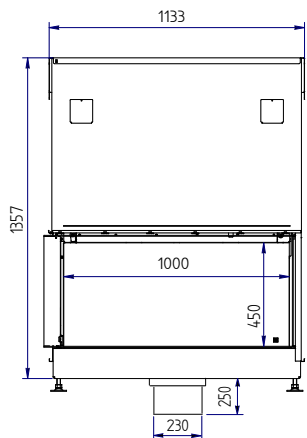

Plan = Luna 1100 CL



output / Leistung	10-15 KW
efficiency / Wirkungsgrad	83 %
weight / Gewicht	320 kg
flue connection / Abgasrohr	Ø 250 mm
chimney / Schornsteindurchmesser	250/250

Automatic door and spark screen not possible.
Automatische Sichtscheibe und Funkenschutzgitter nicht möglich



Luna 750 RD Diamond

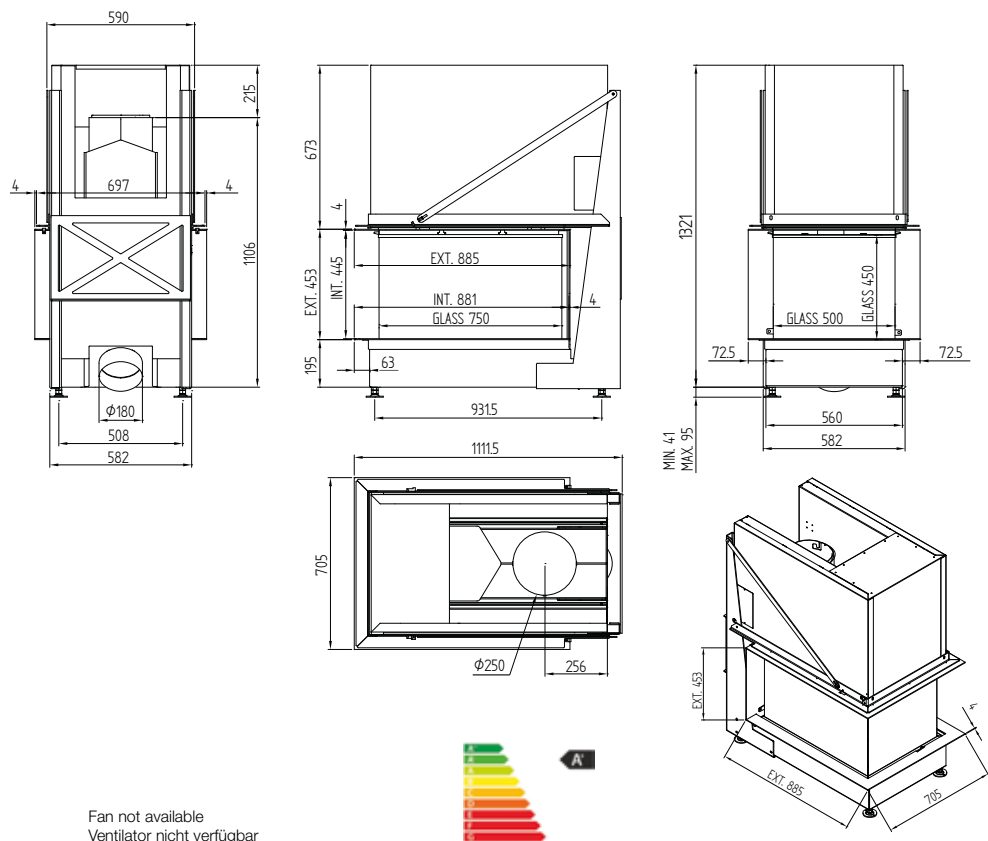

Fan not available
Ventilator nicht verfügbar

Luna 1000 RD Diamond

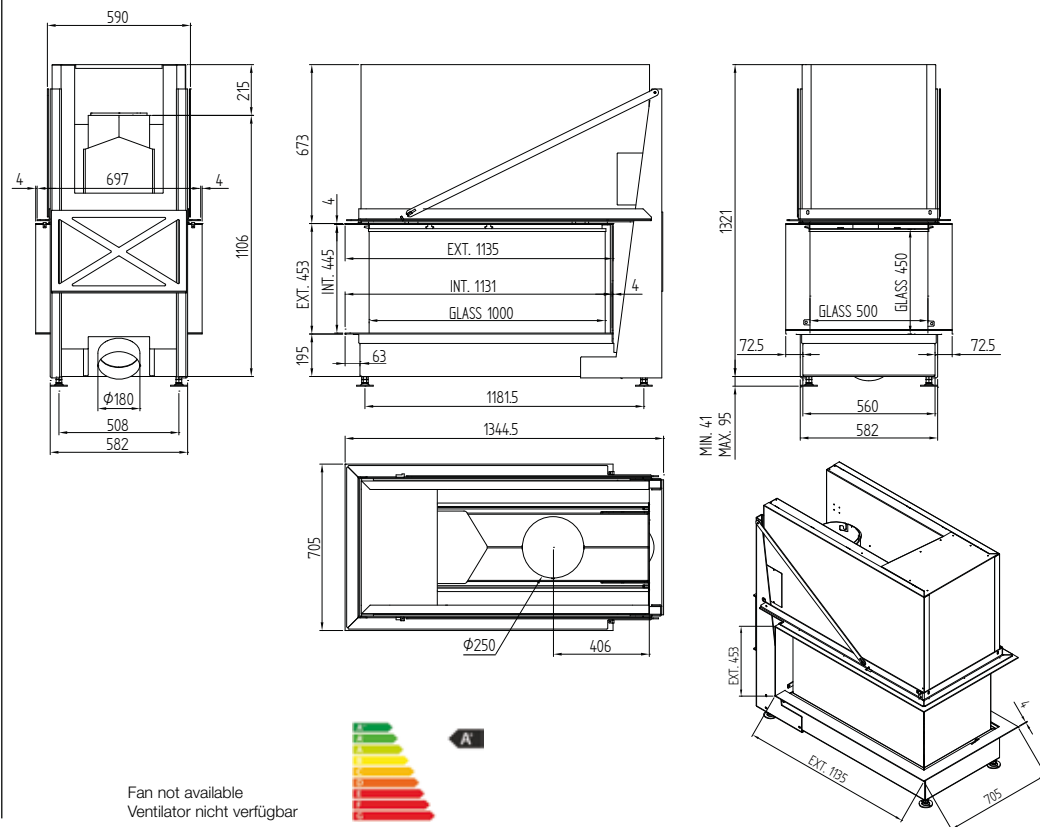

Fan not available
Ventilator nicht verfügbar

output / Leistung	4-14 KW
efficiency / Wirkungsgrad	82 %
weight / Gewicht	330 kg
flue connection / Abgasrohr	Ø 250 mm
chimney / Schornsteindurchmesser	250/250

Automatic door and spark screen not possible.
Automatische Sichtscheibe und Funkenschutzgitter nicht möglich

output / Leistung	5-15 KW
efficiency / Wirkungsgrad	81 %
weight / Gewicht	380 kg
flue connection / Abgasrohr	Ø 250 mm
chimney / Schornsteindurchmesser	250/250

Automatic door and spark screen not possible.
Automatische Sichtscheibe und Funkenschutzgitter nicht möglich





hearts on fire

Are you burning with desire for a warmer atmosphere on cold days? The fireplaces of M-design will surely give you a warm welcome. Allow yourself to delight in our unique designs. You will instantly feel the warm glow in your own living room. The crackling log fire is so inviting... Are you enjoying the delightful smell of wood fire? Can you resist the temptation any longer?

Wünschen Sie sich schon lange eine wärmere Atmosphäre an kalten Tagen? Heizkamine von M-design garantieren Ihnen jederzeit eine wohlfühl Atmosphäre. Unsere einzigartigen Produktmodelle werden Sie wunschlos glücklich machen. Fühlen Sie bereits die wohlige Wärme in Ihrem Wohnzimmer? Hören Sie das Knistern des Feuers? Falls nicht, wie lange können Sie dieser Versuchung noch widerstehen?





inserts

Einbaukassetten

The real heat is inside. Do you have a place or a corner somewhere available in your interior?

The Venus-built-in appliances from M-design allow the primary air to connect directly to the appliance. They function even without a fan when the two top ducts are connected to the convection air.

Die wahre Wärme ist im Inneren. Haben Sie ein wenig Platz in Ihrem Wohnraum? Die M-Design Venus-Einsätze bieten die Möglichkeit, die Verbrennungsluft direkt an den Kamin anzuschließen. Die Geräte funktionieren mit natürlicher Konvektion oder auf Wunsch mit Ventilator.

Venus Green +

sided stove / einseitig page/Seite

Venus 700 Green +	■	50-51
Venus 850 Green +	■	52-53
Venus 1000 Green +	■	54-55

sided stove / einseitig

Venus 630 Green +	■	56-57
Venus 730 Green +	■	56-57

double-sided / Durchsicht

Venus 850 D Green +	□□	58-59
---------------------	----	-------

Interra

sided stove / einseitig

Interra 60	■	62-63
Interra 68	■	64-65
Interra 74	■	64-65
Interra 78	■	66-67

Venus 700 Green +

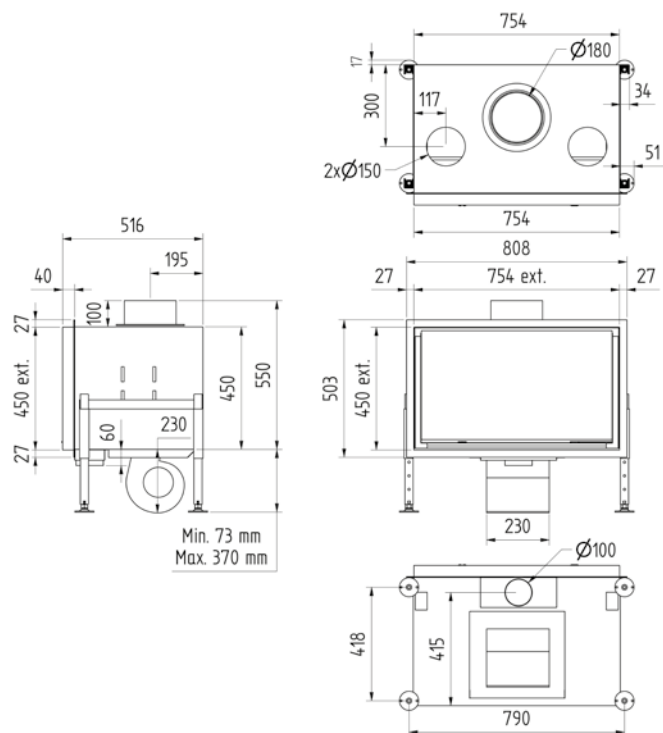

output / Leistung	8-10 KW
efficiency / Wirkungsgrad	78 %
weight / Gewicht	120 kg
finished size / sichtbare Abmessung	754 x 450 mm
flue connection / Abgasrohr	$\text{Ø}180$ mm



Venus 850 Green +

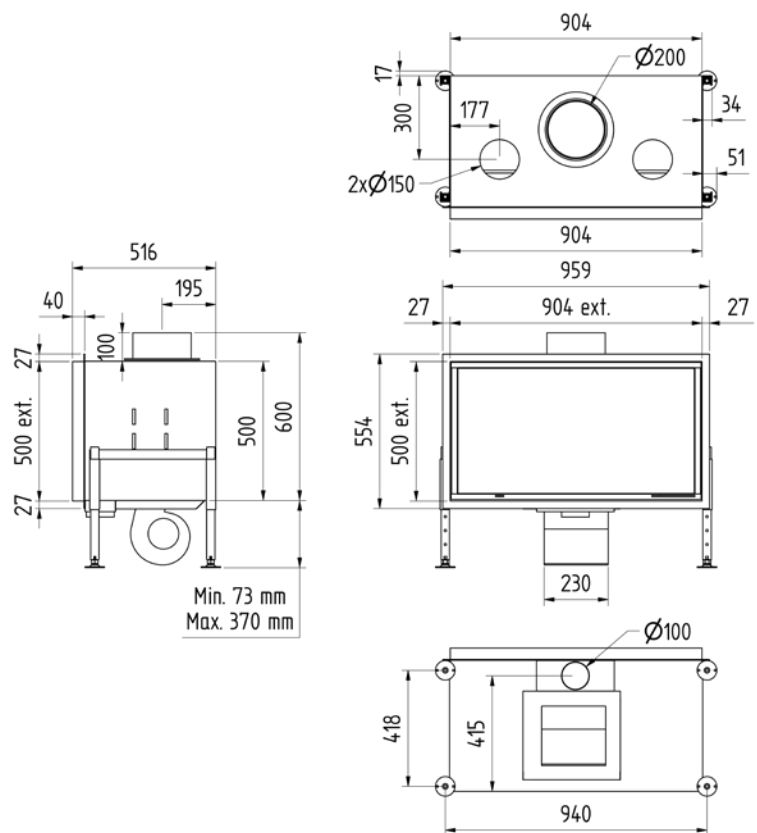

output / Leistung	9-11 kW
efficiency / Wirkungsgrad	79 %
weight / Gewicht	142 kg
finished size / sichtbare Abmessung	904 x 500 mm
flue connection / Abgasrohr	$\varnothing 200$ mm



Venus 1000 Green +

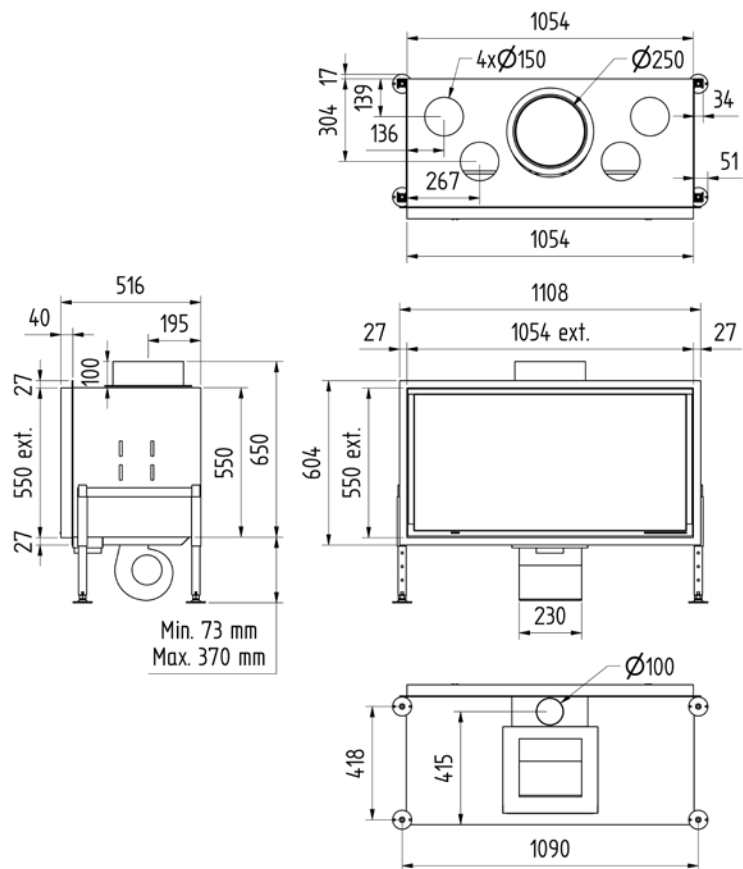

output / Leistung	10-12 KW
efficiency / Wirkungsgrad	77 %
weight / Gewicht	175 kg
finished size / sichtbare Abmessung	1054 x 550 mm
flue connection / Abgasrohr	$\varnothing 250$ mm



Venus 630 Green +

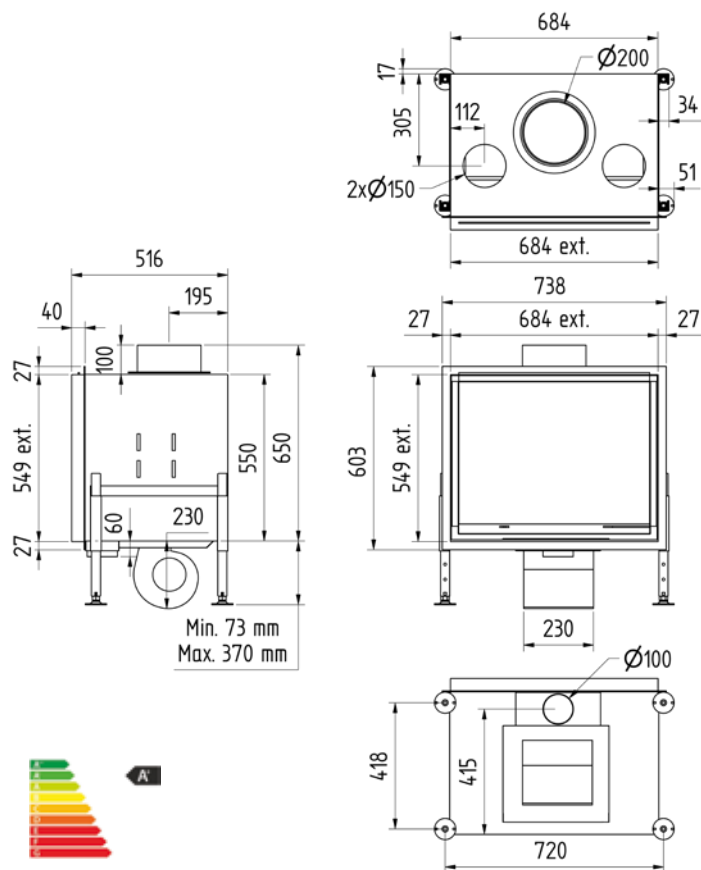

Venus 730 Green +

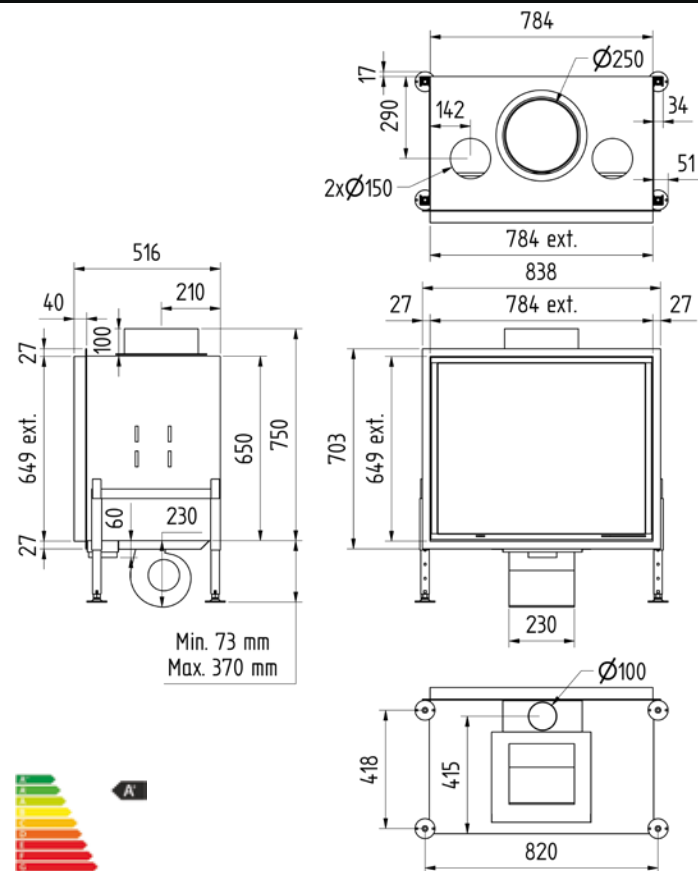

output / Leistung	8-10 KW
efficiency / Wirkungsgrad	79 %
weight / Gewicht	130 kg
finished size / sichtbare Abmessung	684 x 549 mm
flue connection / Abgasrohr	$\text{Ø} 200$ mm

output / Leistung	9-11 KW
efficiency / Wirkungsgrad	77,5 %
weight / Gewicht	140 kg
finished size / sichtbare Abmessung	784 x 649 mm
flue connection / Abgasrohr	$\text{Ø} 250$ mm



Venus 850 D Green +

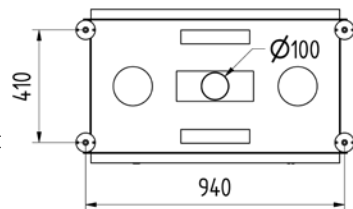
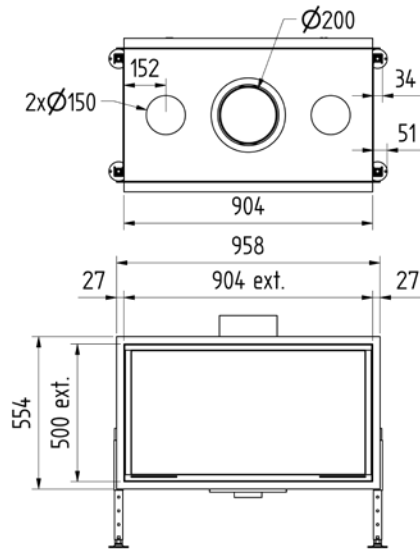
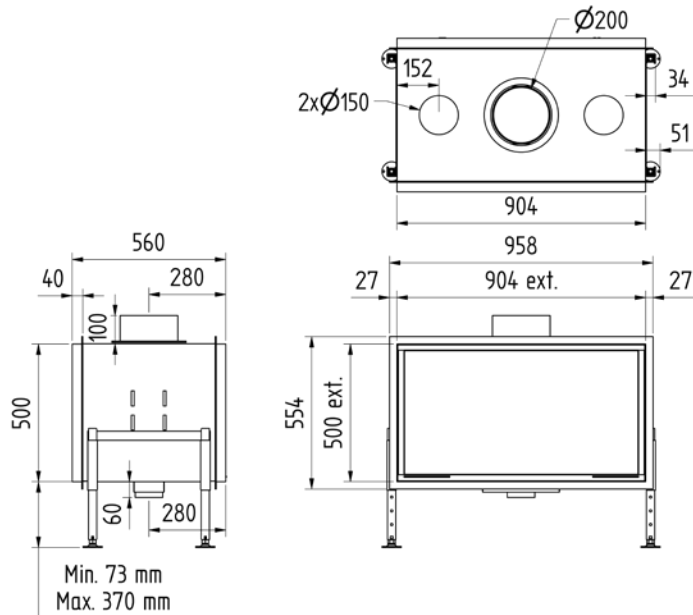

double-sided / Durchsicht

Fan not possible
Ventilator nicht möglich



output / Leistung	9-11 KW
efficiency / Wirkungsgrad	77 %
weight / Gewicht	160 kg
finished size / sichtbare Abmessung	904 x 500 mm
flue connection / Abgasrohr	Ø 200 mm



interra

Interra, the M-design inserts, is the ideal choice for renovating old fireplaces and raising their efficiency. The insert has an integrated fan which distributes the heat in your living room in order to quickly reach the desired temperature. Result: the perfect combination of design and modern combustion technology. If you cannot install the Luna or the Venus appliances due to a lack of space, or if you are not able to connect an external air supply for combustion and cannot provide the convection air channel, then the Interra is the best alternative choice!

Interra, die M-Design Kaminkassette, ist die perfekte Wahl für die Renovierung offener Kamine. Mit Interra wird ihr thermischer Wirkungsgrad multipliziert. Der Einsatz verfügt über einen integrierten Ventilator, der eine schnelle Erwärmung des Zimmers ermöglicht. Die Kaminkassette Interra ist die perfekte Verbindung zwischen Design und moderne Verbrennungstechnologie. Falls der Einbau eines LUNA- oder VENUS-Modelles aus Platzmangel nicht möglich ist, oder es keinen Außenluftanschluss für die Verbrennungs- und Konvektionsluft gibt, ist die Interra Kaminkassette genau das richtige für Sie!





Interra 60

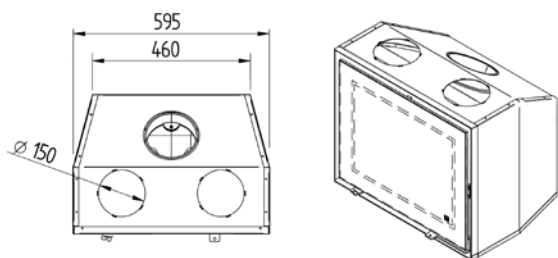
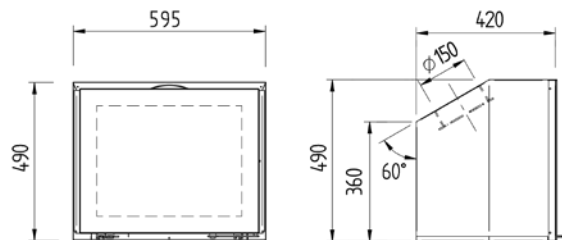

output / Leistung	7 - 9 KW
efficiency / Wirkungsgrad	78,5 %
weight / Gewicht	75 kg
finished size / sichtbare Abmessung	595x490 mm
flue connection / Abgasrohr	Ø 150 mm





Interra 68

Interra 74

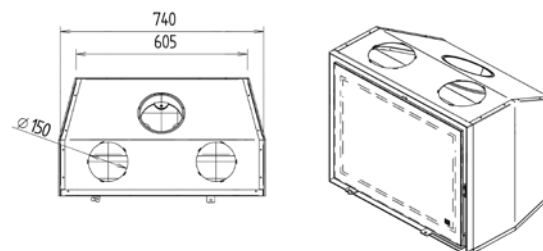
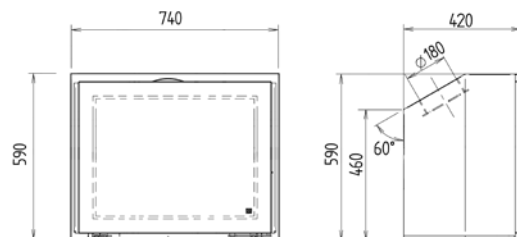
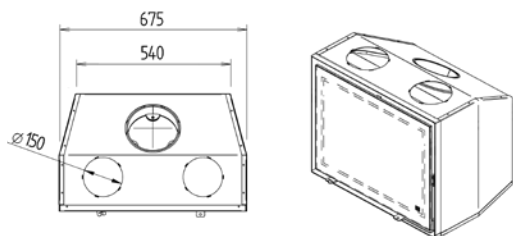
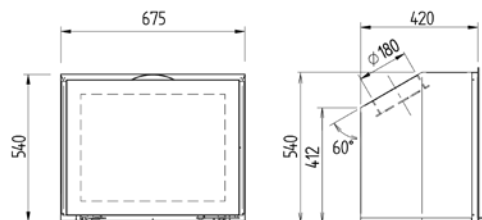

output / Leistung	7 - 10 KW
efficiency / Wirkungsgrad	79 %
weight / Gewicht	87 kg
finished size / sichtbare Abmessung	675x540 mm
flue connection / Abgasrohr	Ø 180 mm

output / Leistung	8,5-11 KW
efficiency / Wirkungsgrad	77,4 %
weight / Gewicht	102 kg
finished size / sichtbare Abmessung	740x590 mm
flue connection / Abgasrohr	Ø 180 mm





Interra 78

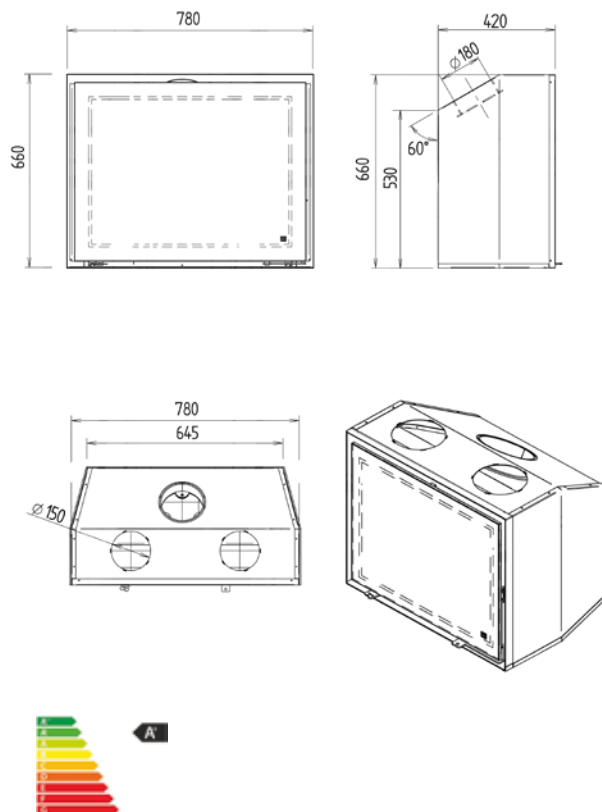

Option Interra : base / Sockel

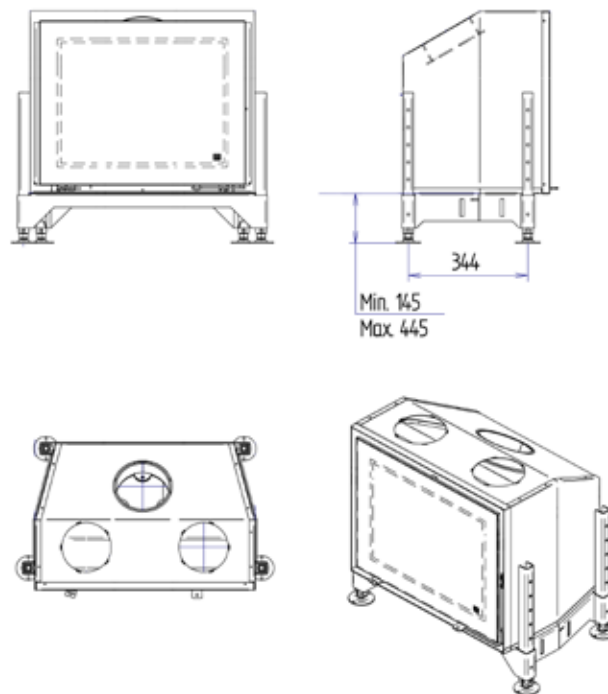

output / Leistung	8 - 12 KW
efficiency / Wirkungsgrad	76 %
weight / Gewicht	114 kg
finished size / sichtbare Abmessung	780x660 mm
flue connection / Abgasrohr	Ø 180 mm







stoves

Kaminöfen

Whoever thinks that stoves are no longer of this time, is completely wrong. One look at the Venus HT says it all. Each model has its own character, but thanks to their timeless design, they will complement any interior. Our stoves have the charm of yesterday with the technology of today.

Unsere qualitativ hochwertigen Öfen sind absolut zeitlos. Ein Beispiel dafür ist das Design unseres Modelles Venus HT.

Jedes Modell hat seine eigene besondere Schönheit und dank ihrer zeitlosen Formen sind sie für jeden Stil geeignet. Der Charme vergangener Zeiten kombiniert mit dem Feuer der heutigen Technologie.

Venus HT

single-sided / einseitig

page/Seite

Venus 700 HT	■	70
Venus 850 HT	■	70
Venus 1000 HT	■	70

double-sided / Durchsicht

Venus 850 DHT	□ □	72-73
---------------	-----	-------

Venus 700 HT

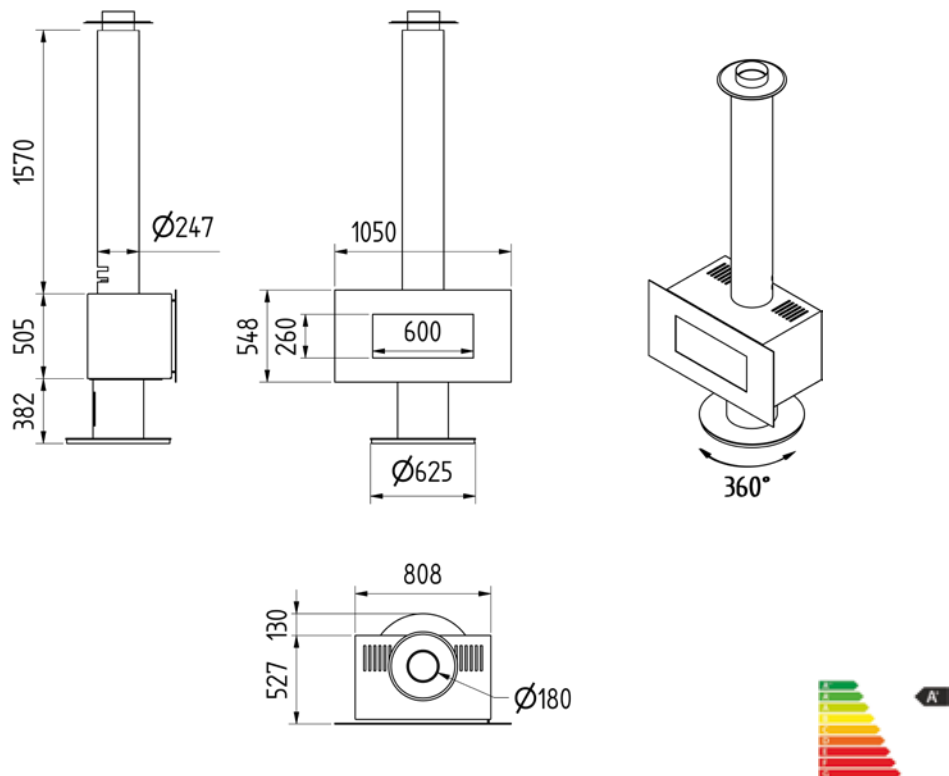

output / Leistung	8-10 KW
efficiency / Wirkungsgrad	79 %
weight / Gewicht	270 kg
flue connection / Abgasrohr	$\varnothing 180$ mm

Venus 850 HT

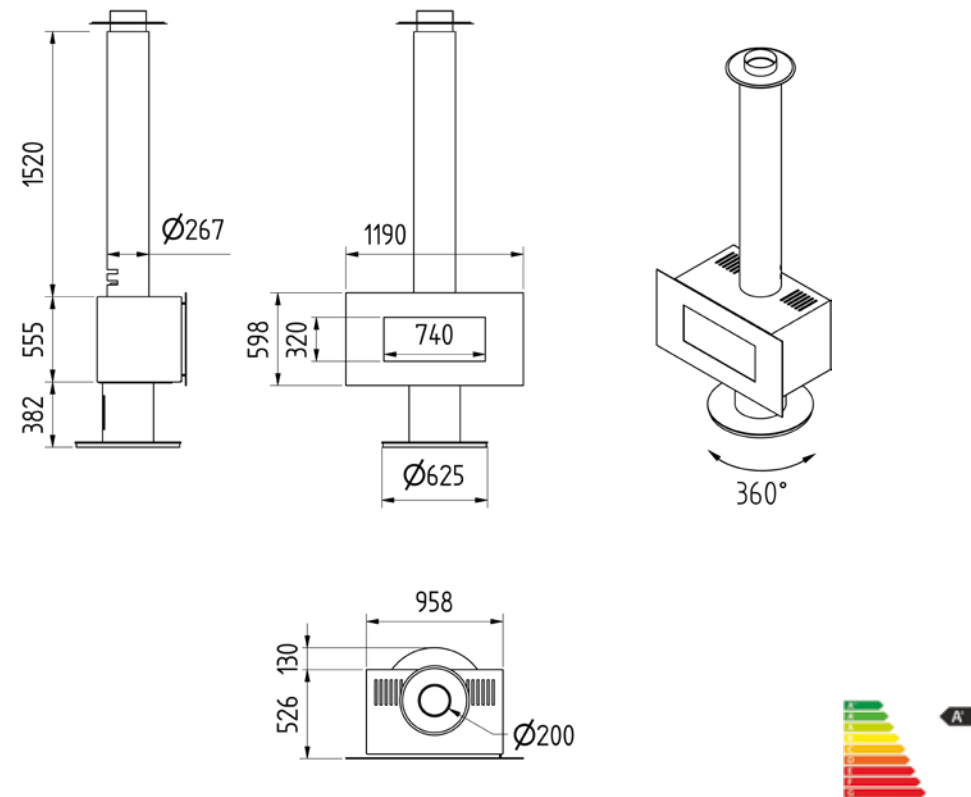

output / Leistung	9-11 KW
efficiency / Wirkungsgrad	79 %
weight / Gewicht	320 kg
flue connection / Abgasrohr	$\varnothing 200$ mm

Venus 1000 HT

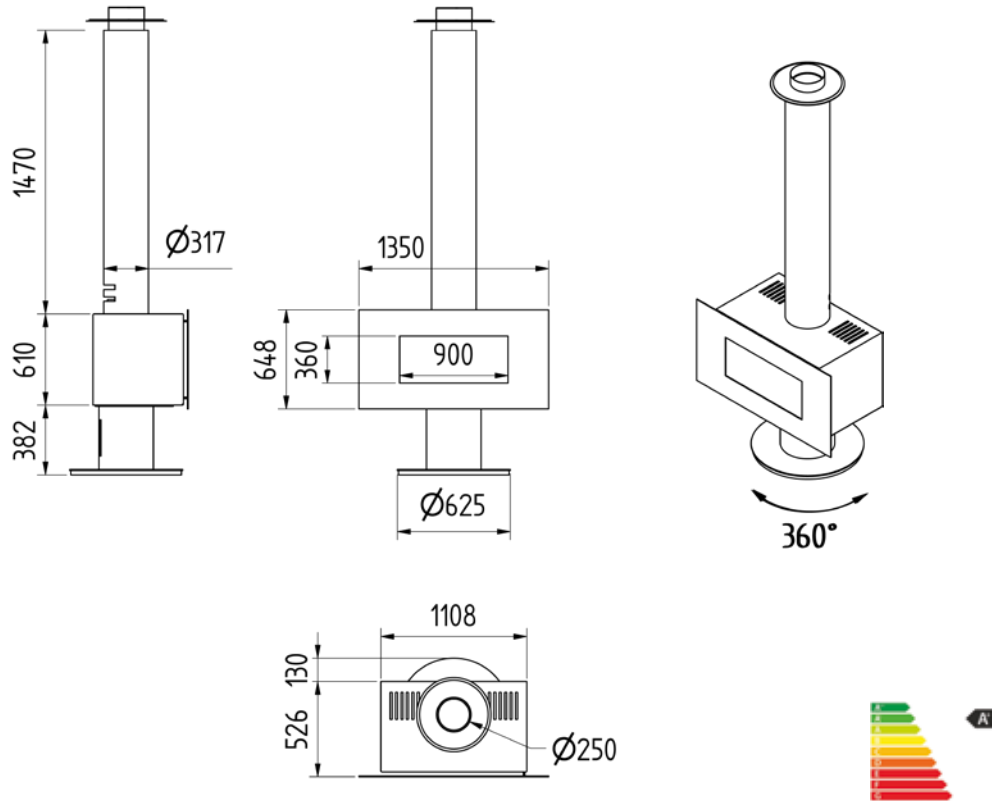

output / Leistung	10-12 KW
efficiency / Wirkungsgrad	79 %
weight / Gewicht	390 kg
flue connection / Abgasrohr	$\text{Ø} 250 \text{ mm}$

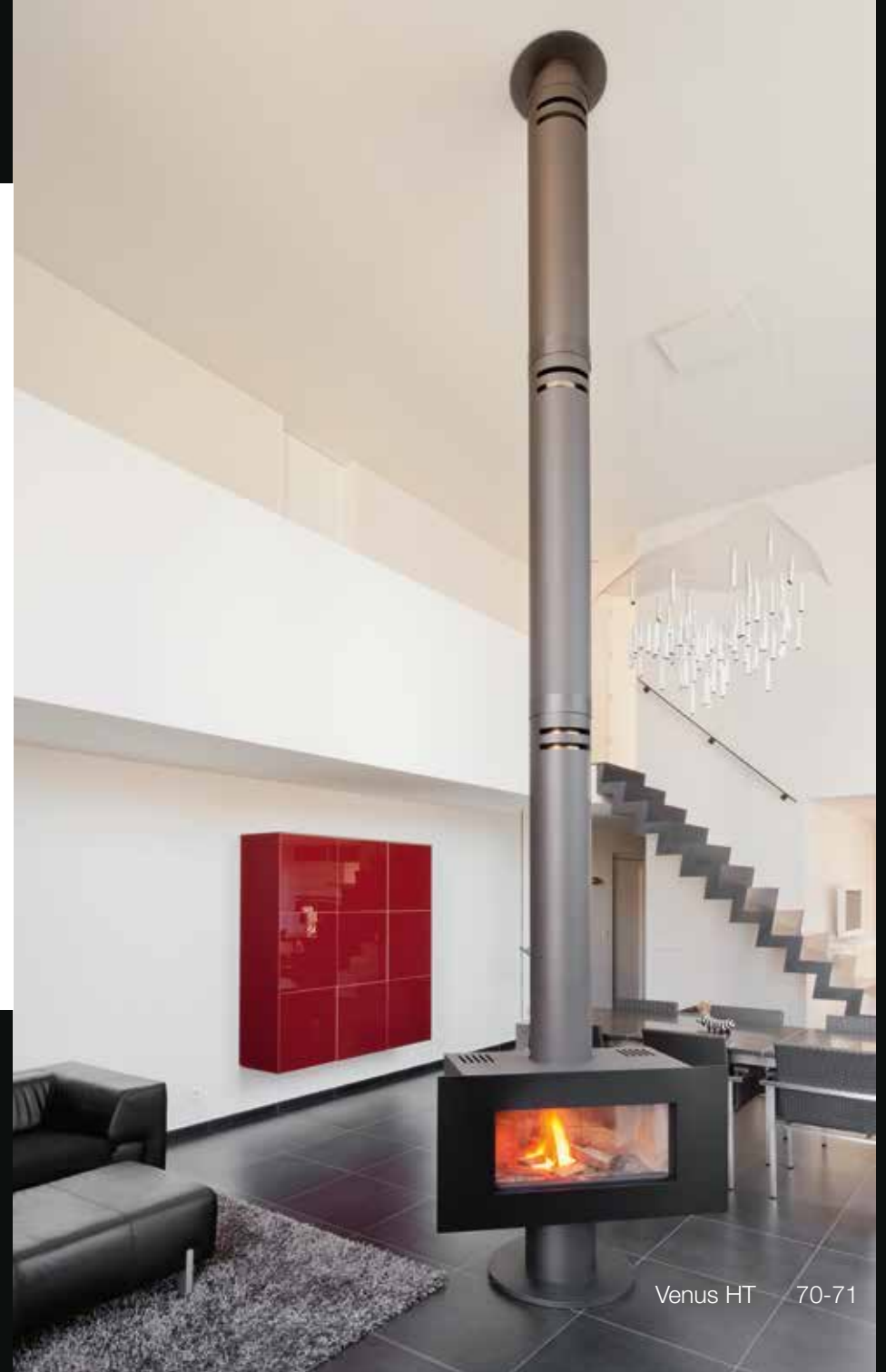

Venus HT 70-71

Venus 850 D HT

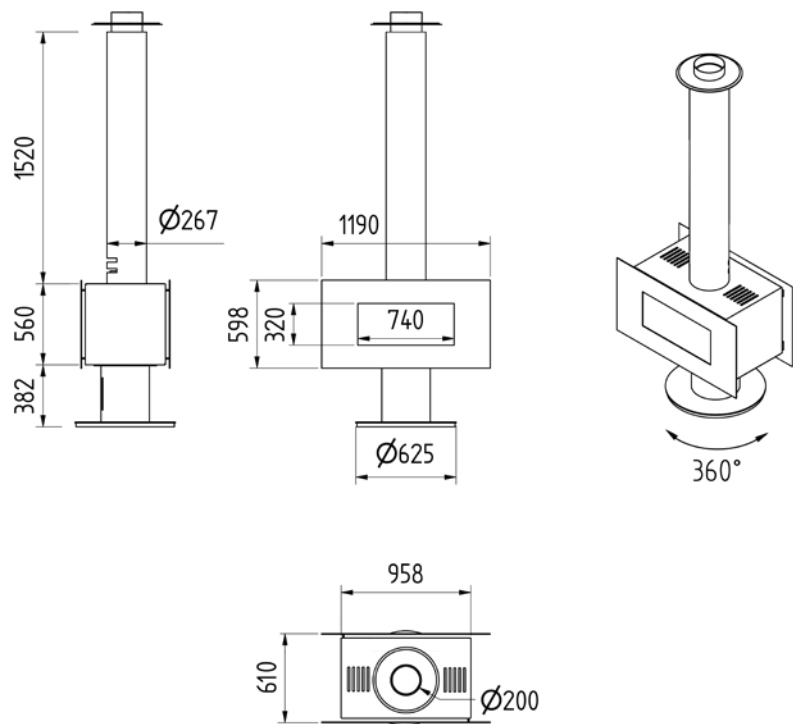

double-sided / Durchsicht



output / Leistung	9-11 kW
efficiency / Wirkungsgrad	77 %
weight / Gewicht	320 kg
flue connection / Abgasrohr	Ø 200 mm



850V BBQ Outdoor Fireplace / Kamin in Freien

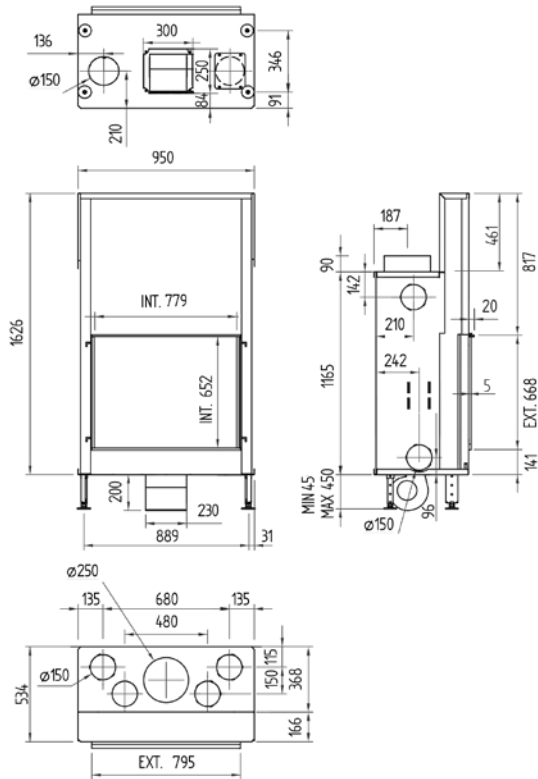

weight / Gewicht	260 kg
finished size / sichtbare Abmessung	779 x 652 mm
flue connection / Abgasrohr	Ø 250 mm
chimney / Schornsteindurchmesser	200/200

The BBQ fireplace has no window, but does have a retractable spark screen, operated manually.
 Der Grillkamin hat kein Fenster, aber eine einziehbare Funkenschutzgitter, die manuell betätigt wird.







Quality warranty Qualitätsmerkmale

1. Automatic lift-door system (only for Diamond Plus)
2. Spark screen
3. Direct connection of fresh air to the unit. This means that we separate the channels for combustion air (in the stove) and convection air (in the living room). The external air can be connected underneath the fireplace. (adaptor piece for connecting this external air from the side is available as an option)
4. System that automatically opens and closes the primary air valve to divert the combustion air when opening or closing the door
5. Baffle plate system. The new patented combustion system ensures optimal combustion and maximum efficiency
6. Manual adjustment of the direct air supply for combustion purposes
7. Convection air intake
8. Warm air vents
9. User-friendly cleaning of the window. This tilts open at a 45° angle
10. Fan (optional)
11. Comes standard delivered with adjustable legs

Warranty

- 8 year warranty on the general structure
- 2 year warranty on internal moving parts and on the smoke damper
- 1 year warranty on fans and dimmer
- No warranty on glass, rope seal and vermiculite interior

Luna Diamond (PLUS) H/V/DH/DV

1. Automatische Sichtscheibe (nur für Diamond Plus)
2. Funkenschutzgitter
3. Externer Verbrennungsluftanschluss. Das heißt, das es getrennte Kanäle für die Verbrennungsluft (im Kamin) und die Konvektionsabluft (im Wohnraum) gibt. Die Verbrennungsluft wird von unten angeschlossen. Mit dem passenden Adapter kann Sie auch seitlich angeführt werden (optional)
4. Bypass-Klappe. Bei Betätigung der Tür öffnet und schließt sich diese automatisch.
5. Umlenkssystem. Das neue patentierte Verbrennungssystem sorgt für eine optimale Verbrennung und maximale Effizienz.
6. Manuelle Regelung der Verbrennungsluft
7. Konvektionszuluft
8. Warmluftausgänge
9. Praktische Klapptüre zur Glasreinigung. Diese hat einen Öffnungswinkel von 45 Grad
10. Ventilator (optional)
11. Höhenverstellbare Füße sind Standard

Garantie

- 8 Jahre Garantie auf den Stahlkörper
- 2 Jahre Garantie auf innenliegende bewegliche Teile
- 1 Jahr Garantie auf alle Elektronikteile
- Wir übernehmen keine Garantie für: Glasbruch, Innenraumauskleidung, Dichtungen und Dekorationsartikel

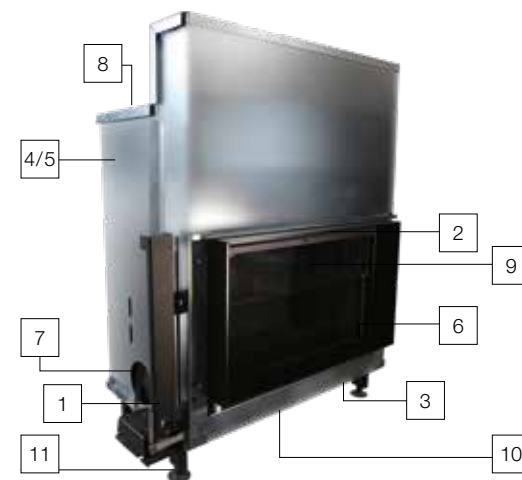



Venus Green +



1. external air supply for combustion
externer Verbrennungsluftanschluß
2. fan (optional)
Ventilator (optional)
3. automatic flue damper
automatische Drosselklappe
4. warm air vents
Warmluftausgänge
5. system with 3 Baffle plates
integrierte Rauchgasumlenkung
6. comes standard with legs adjustable in height
höhenverstellbare FüÙe sind standard



Interra

1. built-in fan (optional)
eingebauter Ventilator (optional)
2. baffle plate system
integrierte Rauchgasumlenkung
3. automatic smoke damper
automatische Drosselklappe
4. warm air vents (not required when using fan or if installed in a non-combustible fireplace)
Warmluftausgänge (mit Ventilator werden keine benötigt)
5. standard delivered without legs, these are optional
wird ohne FüÙe geliefert
Sockel mit FüÙe (optional)

8-year warranty on:
the general structure
8 Jahre Garantie auf
den Stahlkörper. Unsere
Kamine brauchen keinen
Feinstaubfilter.



PASSION FOR FIRE

Luna Diamond RD



1. Metal sheet that covers unlocking lift-door system
2. Unlocking of lift-door system
3. Direct connection of fresh air to the unit. This means we separate the channels for combustion air (in the stove) and convection air (in the living room)
4. Manual adjustment for the direct air supply for combustion purposes
5. Device may only burn closed
6. User-friendly cleaning of the window. This tilts open at a 45° angle.
7. Comes standard delivered with adjustable legs.
8. Convection air intake
9. Warm air vents

The hot air vents can't be connected using (ducting) flexible tubes. Sufficient Convection flow must be provided at all times.

1. Abdeckung Transportsicherung des Türsystems
2. Transportsicherung Entriegelung
3. Externer Verbrennungsluftanschluss. Das heißt, das es getrennte Kanäle für die Verbrennungsluft (im Kamin) und die Konvektionsabluft (im Wohnraum) gibt.
4. Verbrennungslufthebel
5. Kamin nur für den geschlossenen Betrieb geeignet.
6. Praktische Klapptüre zur Glasreinigung. Diese hat einen Öffnungswinkel von 45 Grad.
7. Höhenverstellbare Füße sind Standard
8. Konvektionszuluft
9. Warmluftausgänge

An die Warmluftauslässe können keine flexibelen Schläuchen angeschlossen werden. Eine ausreichende Konvektionsströmung muß immer vorhanden sein.

Luna Diamond CL/CR/DC

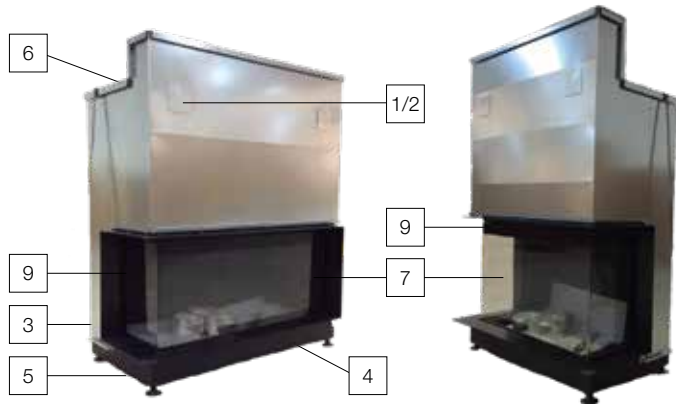

1. Metal sheet that covers unlocking lift-door system
2. Unlocking of lift-door system
3. Direct connection of fresh air to the unit. This means we separate the channels for combustion air (in the stove) and convection air (in the living room)
4. Manual adjustment for the direct air supply for combustion purposes
5. Convection air intake
6. Warm air vents
7. User-friendly cleaning of the window. It moves forward horizontally.
8. Comes standard delivered with adjustable legs.
9. Sport mode (situated in the corner)
10. Fan adapter

1. Abdeckung Transportsicherung des Türsystems
2. Transportsicherung Entriegelung
3. Externer Verbrennungsluftanschluss. Das heißt, das es getrennte Kanäle für die Verbrennungsluft (im Kamin) und die Konvektionsabluft (im Wohnraum) gibt.
4. Manuelle Regelung der Verbrennungsluft
5. Konvektionszuluft
6. Warmluftausgänge
7. Benutzerfreundliche Reinigung des Fensters. Es bewegt sich vorwärts horizontal.
8. Höhenverstellbare Füße sind Standard
9. Sportmodus (befindet sich im Ecke)
10. Ventilator-Adapter

Luna Diamond

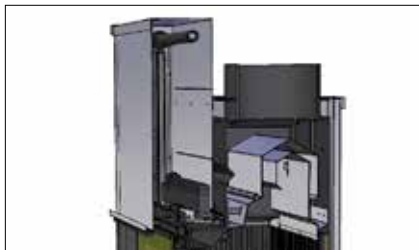

new patented combustion system
neues patentiertes Verbrennungssystem

New: chimney-sweep-friendly thanks to a valve system.
Neu: Benutzerfreundliche Reinigung für Schornsteinfeger durch eine Klappesystem



spark screen (manually operated)
Funkenschutzgitter (manuell zu bewegen)

not possible with / nicht möglich bei:
550 V - 900 CL/CR - 1100 CL/CR - 800 DC
1000DC - 750RD - 1000RD



Comes standard with "O" frame
Rahmen "O" ist standard

inner frame "O"
Innenrahmen "O"



fan 600 m³
Ventilator 600 m³

not possible with double-sided appliances and roomdivider
nicht möglich bei Durchsichtgeräte und roomdivider

fan 350 m³
Ventilator 350 m³
for / für 550V

Option Luna Diamond

standard delivered with vermiculite
interior metal interior is optional
Kommt standard mit Chamoflex.
Metallauskleidung im Feuerraum
Optional



Metal cast
Feuerraumauskleidung Stahl Schwarz



Iron cast / Feuerraumauskleidung Guss

reversibel
reversibel



Fine ribbed / Fein gerillt



Wide ribbed / Groß gerillt

The flue's minimum height

with regard to its reduction

Mindesthöhe und Mindestdurchmesser

des Schornsteines bei offenen Betrieb

	Ø300	Ø250	Ø200	Ø180	Ø150	External air supply for combustion
Luna Diamond (Plus)						
Luna 700 H +			>4m	>7m		1 Ø150
Luna 850 H +		≥4m	>4m	>7m		1 Ø150
Luna 1000 H +		≥4m	>5m			1 Ø150
Luna 1150 H +		≥4m	>6m			1 Ø150
Luna 1300 H +		≥5m	>8m			1 Ø150
Luna 550 V +		≥4m	>5m	>7m		1 Ø150
Luna 850 V +		≥5m	>7m			1 Ø150
Luna 1000 V +		≥6m	>8m			2 Ø150
Luna 1150 V +		≥7m	>9m			2 Ø150
Luna 850 DH +	≥5m	≥7m				2 Ø150
Luna 1150 DH +	≥6m	≥8m				2 Ø150
Luna 850 DV +	≥6m	≥8m				2 Ø150
Luna 1000 DV +	≥7m	≥9m				2 Ø150
Luna 800 DC			>6m			1 Ø150
Luna 1000 DC		≥5m	>9m			1 Ø150
Luna 900 CL/CR +		≥5m	>7m			1 Ø150
Luna 1100 CL/CR		≥6m	>9m			1 Ø150
Luna 750 RD		≥5m				1 Ø180
Luna 1000 RD		≥6m				1 Ø180

		Ø250	Ø200	Ø180	Ø150	Extern Luft für Verbrennung
Venus Green plus	-					
Venus Green 630 +			≥4m	≥6m		1 Ø100
Venus Green 730 +		≥4m	≥6m			1 Ø100
Venus Green 700 +				≥4m		1 Ø100
Venus Green 850 +			≥4m	≥6m		1 Ø100
Venus Green 1000 +		≥4m	≥6m			1 Ø100
Venus Green 850 D +			≥4m	≥6m		1 Ø100
Venus Green 700 HT +				≥4m		
Venus Green 850 HT +			≥4m	≥6m		
Venus Green 1000 HT +		≥4m	≥6m			
Venus Green 850 DHT +			≥4m	≥6m		

The chimney flue must be built under strict conditions. Certain chimney configurations may demand a different diameter than the standard one. In such cases, please refer to the table for the height of the flue and the possibility to reduce it with a reduction piece.

Note: per 45° change of direction (= 2x 45° bend) add 1 m to the measurements in the table.

- The flue needs to be thermally insulated. The exit of the chimney and its position are extremely important.
- An individual flue cannot have more than two changes in direction.
- The corner of these changes in direction cannot be greater than 45° with its perpendicular.
- The existing hindrances in the vicinity of the chimney exit must be taken into account
- Do not connect more than one appliance per flue: choose the best and close off the ones that are not used.

Fireplaces can only burn with the door open under 'ideal conditions'

Der Schornstein ist der Motor Ihrer Feuerstätte, daher sollten gewisse Aspekte unbedingt eingehalten werden. Der Schornsteinquerschnitt und die wirksame Schornsteinhöhe müssen zur Feuerstätte passen. Die mögliche Größe der Feuerstätte ist abhängig vom Querschnitt und der wirksamen Schornsteinhöhe.

Gemessen vom Rauchrohranschluss am Schornstein bis zum oberen Ende des Schornsteins (Mündung), muss der Schornstein mind. 5 Meter hoch sein.

- Auch eine Berechnung nach DIN 13384 kann einen Funktionsnachweis bei geringerer als der geforderten Höhe erbringen. (Dies kann ein Fachbetrieb oder Ihr Schornsteinfeger für sie errechnen).
- Beachten Sie, dass wenn Ihr Schornstein nicht den Mindestanforderungen entspricht, sie sich evtl. für ein kleineres Gerät entscheiden müssen.
- In jedem Fall sollten Sie sich mit einem kompetenten Fachbetrieb vorher beraten.
- Die Tabelle sollte Ihnen einen kleinen Anhaltspunkt bei Ihrer Entscheidung geben.

Ein offener Betrieb des Kamins ist nur möglich, wenn es die Bedingungen zulassen.

Frames Rahmen

Luna Diamond

single face and double-sided models / Einseitig- und Durchsichtmodelle

3D

3D ADJUSTABLE LUXURY INNER FRAME 8MM THICKNESS /
3D JUSTIERBARER DESIGNRAHMEN MIT 8 MM STÄRKE
(optional / optional)

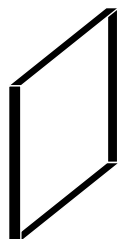

4,5 cm **FINISHED SIZE / AUSFÜHRUNGSMASS**
C = 4,5 cm - 4 sides / 4 Seiten
adjustable to 5 cm / justierbar bis 5 cm

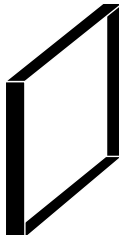

7,5 cm **FINISHED SIZE / AUSFÜHRUNGSMASS**
C = 7,5 cm - 4 sides / 4 Seiten
adjustable to 8 cm / justierbar bis 8 cm

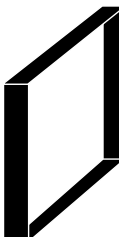

10,5 cm **FINISHED SIZE / AUSFÜHRUNGSMASS**
C = 10,5 cm - 4 sides / 4 Seiten
adjustable to 11 cm / justierbar bis 11 cm



2 cm **DESIGN FRAME / DESIGN-Rahmen C = 2,5 cm**
3 sides / 3 seiten - 4 sides / 4 Seiten

The design frame needs to be mounted onto an inner frame /
Der Design-Rahmen muss auf einem Innenrahmen montiert werden

Luna Diamond

corner and double corner models / Eck- und Doppelleckmodelle

INTERIOR FRAME / INNENRAHMEN 4 MM



FINISHED SIZE / AUSFÜHRUNGSMASS
6,8 cm
6 sides / 6 Seiten - 8 sides / 8 Seiten

comes standard with this appliance /
kommt standard mit diesem Gerät

**C = FINISHED SIZE /
C = AUSFÜHRUNGSMASS**

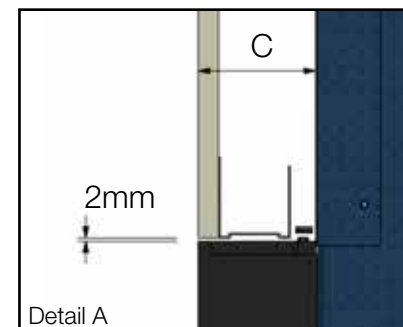
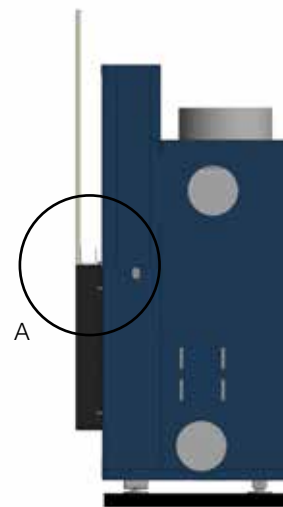

collection
DIAMOND
The victory of fire

Venus Green+

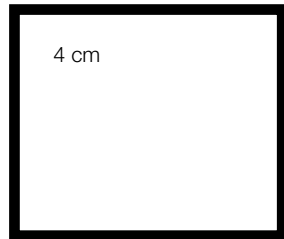

DESIGN FRAME 4 cm
DESIGN RAHMEN 4 cm
4 sides / 4 seiten

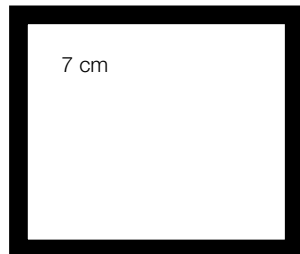

DESIGN FRAME 7 cm
DESIGN RAHMEN 7 cm
4 sides / 4 seiten

Interra

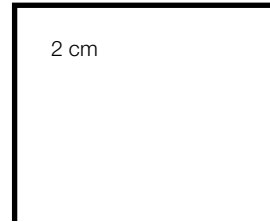

DESIGN FRAME / DESIGN RAHMEN 2 cm
3 sides / 3 seiten
4 sides / 4 seiten

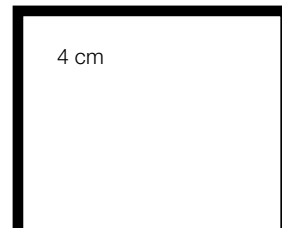
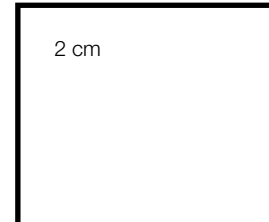

DESIGN FRAME / DESIGN RAHMEN 4 cm
3 sides / 3 seiten
4 sides / 4 seiten

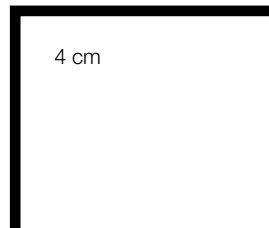

Venus HT

A B



DECORATIVE DOOR-FRAME / DESIGN RAHMENTÜR
comes standard with big door-frame /
kommt standard mit großer Rahmentür

Venus 700 HT

Big door-frame / Große Rahmentür 1050 x 548 mm A
Small door-frame / Kleine Rahmentür 848 x 548 mm B

Venus 850 HT

Big door-frame / Große Rahmentür 1190 x 598 mm A
Small door-frame / Kleine Rahmentür 998 x 598 mm B

Venus 1000 HT

Big door-frame / Große Rahmentür 1350 x 648 mm A
Small door-frame / Kleine Rahmentür 1148 x 648 mm B

Extra

Design convection outlets / Designgitter Mod. dep. n° 000483359-0001

Finished size / sichtbare Abmessung 250 x 200 mm

Installation size / Einbaumaß 230 x 180 mm

Finished size / sichtbare Abmessung 1223 x 82 mm

Installation size / Einbaumaß 1200 x 64 mm

Finished size / sichtbare Abmessung 420 x 82 mm

Installation size / Einbaumaß 407 x 67 mm

Air supply grill / Lüftungsgitter

Finished size / sichtbare Abmessung 200 x 200 mm

Installation size / Einbaumaß 176 x 181 mm

Finished size / sichtbare Abmessung 250 x 100 mm

Installation size / Einbaumaß 230 x 80 mm

General accessories / Zubehör

Bio-Clean M-Design

High-teflon oil / High-teflon Öl

Aerosol black or anthracite / Farbsprühdose Schwarz oder Anthrazit

Ash-cleaner / Aschenschaufel

1



2



3

4



5

Grill colour range

Farben Design- und Lüftungsgitter

white
Weiß 

grey
Grau 

alu
Alu 

black
Schwarz 



4



5



Fuels Brennstoffe

The quality of the wood is very important if you want to get an optimal result from your wood fireplace. In order to get this required quality, wood must be covered in a ventilated storage for at least two years to dry. The correct way to cover wood is to place a protective shield on top of the wood. The other sides need to be free so the wood can 'breathe' and dry. If this is not done correctly, the wood will get wet and will rot. Wet wood logs (50% or more moisture) produce less heat and cause soot damage to the stove and chimney. The water in the wood absorbs a large amount of energy during the combustion. The logs cook rather than burn and therefore lose quite a lot of calorific heat.

Die Qualität des Brennstoffs ist von größter Bedeutung für eine optimale Funktion Ihres Kamins. Eine gute Brennstoffqualität ist ein trockenes Holz, das 2 Jahre an einem vor Regen geschützten sonnigen belüfteten Platz (unter 18 % Resfeuchte) gelagert wird. Die Trocknung des Holzes ist sehr wichtig. Achten sie darauf, dass beim Abdecken des Holzes mit einer Plane die Feuchtigkeit entweichen kann (Verrottung und Schimmelbildung vermeiden). Beim Betrieb Ihres Kamins mit nassem Holz ist der Heizwert nicht gegeben.

NEVER USE

The use of treated wood (painted, impregnated etc.) and household waste, which can spread harmful gases during combustion, is prohibited. The use of these will negate your warranty on the appliance. Pallet wood and other waste wood have a high heat release. Using this wood can therefore lead to overheating, which results in fire hazard. M-design is not responsible for the incorrect use of fireplaces and noncompliance with these directives (see warranty conditions). The use of petroleum cokes as fuel and liquid fuels (gasoline etc.) is also prohibited, even for starting the fire. There is no use

Auch ist eine Verschmutzung der Sichtscheibe, des Feuerraumes und des Schornsteins gegeben. Die meiste im Holz gespeicherte Energie muss zur Trocknung des Holzes und nicht zum Heizen des Kamins verwendet werden.

VERBOTEN BRENNSTOFFE

Behandeltes Holz (lackiert, beschichtet, etc. ..), darf nicht verheizt werden (Umweltverschmutzung). Holzpaletten, Spanplatten und andere Holzabfälle erzeugen sehr hohe Temperaturen, dies kann zu einer Überhitzung des Kamins führen.

in overloading the fireplace with wood. If the draft in the chimney becomes too strong, the fire can reach excessively high temperatures. The damage caused by overloading your fireplace is not covered by the warranty.

Bei Nichtbeachtung erlöschen die Garantieansprüche. Der Einsatz von flüssigen Brennstoffen (Benzin, Brennspiritus usw.) ist verboten! (Explosionsgefahr) Achten Sie auf die maximale Brennstoffmenge um den Kamin nicht zu überheizen. Dadurch entstehende Schäden am Kamin sowie in den Wohnräumen durch zu hohe Temperaturen. Diese sind nicht durch die Garantie abgedeckt.

How can you see that the wood is too moist or unfit for use?

- Problems with the lighting of the fire
- An excessive amount of smoke and a low flame
- Glass becomes black very quickly
- Abundant formation of creosote.
- Low heat.
- Smell of smoke in the house.
- The fire burns too shotly.
- You need too much wood.
- White, greyish and dense smoke.

Die Symptome, die Sie beobachten, wenn Ihr Holz zu naß ist.

- Probleme beim Anzünden des Kamins (brennt nicht)
- Große Menge von Rauch und kleine Flamme
- Verrußen der Sichtscheibe · Unverbranntes Holz und viel Asche · Geringe Wärmeausbeute · Rauch im Wohnraum · Schlechte Verbrennung mit Geruchsbelästigung
- Sehr dichter, weißer und grauer Rauch

Wood type Holzart	Calorific value Heizwert	Quality of wood log Eigenschaften der Holzarten	Comments Bemerkungen
Hardwood: Hornbeam, Beech, Oak, Ash	High	Very slow combustion	Excellent hardwood
Hartholz: Hainbuche, Buche, Eiche, Esche	Hoch	Sehr langsame Verbrennung	Perfektes Brennholz bei vorhandenem Glutstock (Eiche kleine Flammen)
Medium-hard wood: Cherry, fruit trees, Walnut	Average	Slow combustion	Dry walnut loses its sharp density; not be used in a chimney: spark hazard.
Medium-hartes Holz: Erle, Obst- und Nussbäume, Birke	Gut	Langsame Verbrennung	Gutes Brennholz
Soft wood: Birch, Alder, Poplar	Low	Rapid combustion	Any piece of soft or medium wood will progress the lighting of the fire.
Weichholz Fichte, Tannen, Kiefer, Erle	Duchschnittlich	Schnelle Verbrennung	Sehr gut geeignet zum Anzünden eines Kamins. Schnelle hohe Temperaturen. Geeignet für einen schnellen Temperaturanstieg.
Soft wood: resin trees Pine, Coniffer	Low	Rapid combustion	Has a reputation of pulluting the chimneys.
Weichholz Pappel, Birke	Niedrig	Schnelle Verbrennung	Hohe Asche Bildung. Kaum Heizleistung.



8-year warranty on:
the general structure
8 Jahre Garantie auf
den Stahlkörper. Unsere
Kamine brauchen keine
Feinstaubfilter.



PASSION FOR FIRE

Notes
Notizen



Notes
Notizen



Zelfs indien wij alle mogelijke middelen aanwenden om u de beste service te verlenen, zijn wij niet gevrijwaard tegen menselijke en/of mechanische fouten. Het kan voorkomen dat bepaalde informatie verouderd is, daar wij onze producten blijven optimaliseren. Bepaalde producten kunnen dus verschillen ten opzichte van de illustraties in deze catalogus. M-Design behoudt het recht prijzen en/of modellen te veranderen zonder voorafgaand bericht en verwerpt elke verantwoordelijkheid bij juridische vervolging op basis van deze catalogus.

Même si nous prenons tous les moyens nécessaires afin de vous offrir le meilleur service possible, nous ne sommes pas à l'abri d'erreurs humaines ou mécaniques. Il se peut que certaines informations soient obsolètes, car nous continuons à améliorer et optimiser nos produits. Certains produits peuvent être différents de l'illustration figurant dans ce catalogue. M-Design se réserve le droit de modifier prix et/ou caractéristiques techniques de ses appareils sans préavis et rejette toute responsabilité d'une poursuite judiciaire uniquement sur la base du catalogue.



Het papier gebruikt voor deze catalogus is afkomstig uit een duurzaam beheerd bos.

Le papier utilisé pour ce catalogue provient d'une forêt gérée durablement.



PASSION FOR FIRE



BEZOEK ONZE WEBSITE
CONSULTEZ NOTRE SITE WEB

VISIT OUR WEBSITE
BESUCHEN SIE UNSERE WEBSITE



V2022/01

WWW.M-DESIGN.BE

